

Holman

Instruction Guide

81002

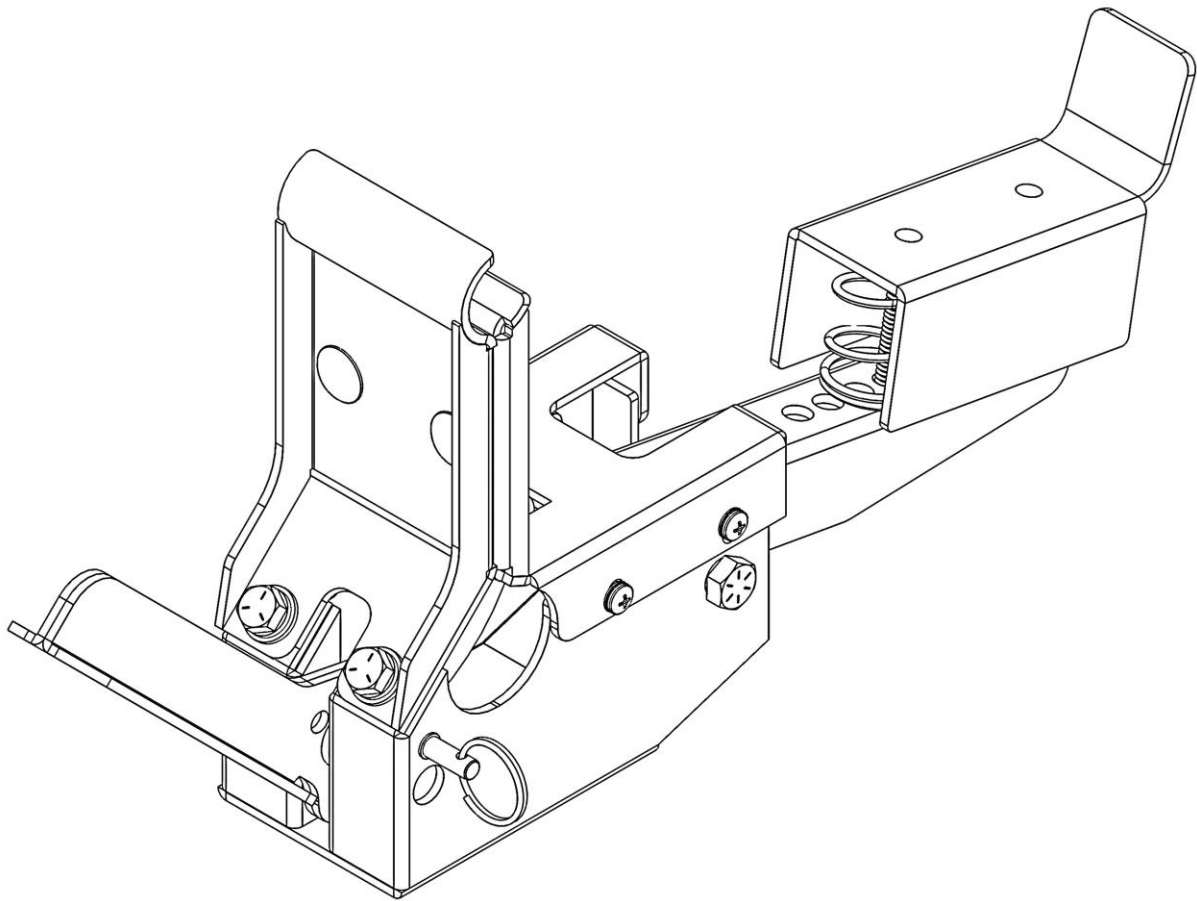

Holman
Rancho Cordova, CA 95742
800-343-7486
InstallationSupport@holman.com

PLEASE READ ALL INSTRUCTIONS AND WARNINGS PRIOR TO ASSEMBLING, INSTALLING, AND USING THIS PRODUCT.

Warning



DO NOT EXCEED MANUFACTURERS WEIGHT CAPACITY FOR ROOF.



Always ensure lock pin is in lock position and clamp is properly adjusted before transporting any ladder.

Tools Needed

1/2" Socket and Wrench	#2 Phillips Screwdriver
1/2" Box Wrench	

Table of Contents

Before You Begin 1

Parts 2

Hardware 3

Step 1 – Disassemble Clamp Assembly 4

Step 2 – Determine Ladder Clamp Location 4

Step 3 – Adjust Ladder Hook Height 4

Step 4 – Attach Front Clamp 5

Step 5 – Attach Rear Clamp 5

Step 6 – Adjust for Ladder 6

Before You Begin

- Read all instructions prior to assembling or installing any Holman product.
- **Always locate your installation locations prior to performing any work.**
- **Have rack assembled prior to installation of clamp mechanism.**
- **Secure all payloads properly for safe transportation.**



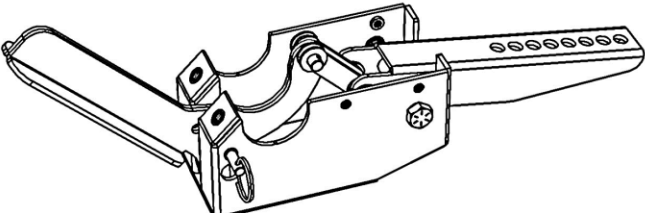
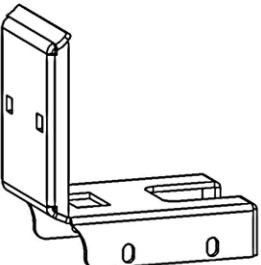
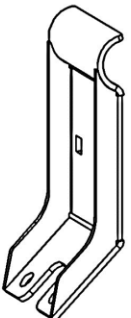
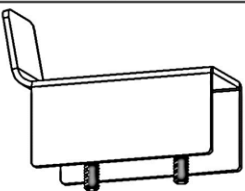

Parts

With the exception of the tape strip, the clamp comes preassembled. The following parts are for identification during installation.

NO.	ITEM	PART NUMBER	DESCRIPTION	QTY.
1		81002-01	SWING ARM AND HOOK ASM	1
2		81002-002	CLAMP, REAR	1
3		81002-009	CLAMP, FRONT	1
4		81002-010	LADDER HOOK	1

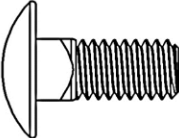
Hardware

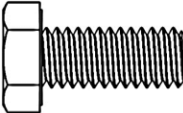
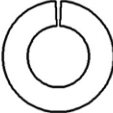
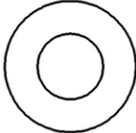
With the exception of the tape strip, the clamp comes preassembled. The following hardware is for identification during installation.

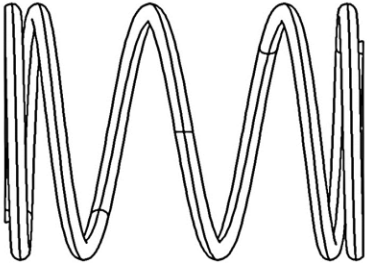
ITEM	HARDWARE TO SCALE	PART NUMBER	DESCRIPTION	QTY.
1		21810	5/16"-18 X 3/4" CARRIAGE BOLT	2
2		11104019	5/16-18 FLANGED NYLOCK NUT	4
3			5/16-18 X 3/4" HEX HEAD BOLT	2
4		1133620	5/16" LOCKING WASHER	2
5		33080	5/16" WASHER	2
6			#10-32 X 1/2" PAN HEAD SCREW W/ LOCK WASHER	4
7			SPRING 1.875X1.312X.093	2
8			UHMW TAPE 1.625" X 3"	1

DO NOT EXCEED MANUFACTURERS WEIGHT CAPACITY FOR ROOF

Step 1 – Disassemble Clamp Assembly

- Release ladder hook by pulling pin on side of swing arm.
- Pull handle outward.
- Remove 5/16" x 3/4" hex head bolts, 5/16" lock washers, and 5/16" flat washers from swing arm assembly.
- Remove 5/16" x 3/4" carriage bolts and 5/16" flanged lock nuts from front and rear clamps.
- Remove #10 x 1/2" pan head screws from rear clamp and swing arm assembly.

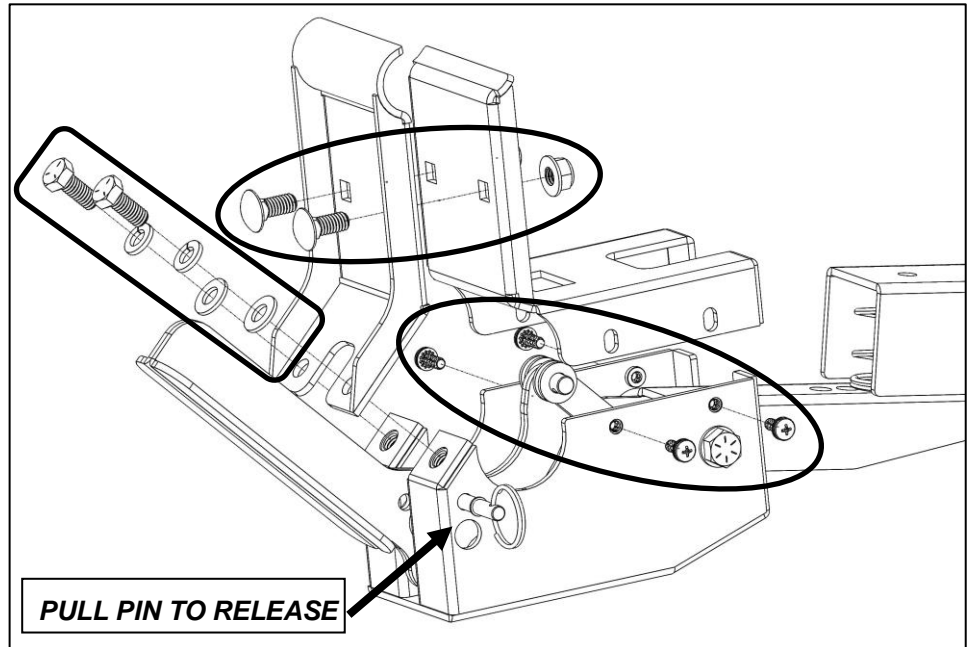

Step 2 – Determine Ladder Clamp Location

- Determine the location to install ladder clamp. Position ladder clamp about center between crossbars on the ladder or about centered on the ladder.

Step 3 – Adjust Ladder Hook Height

- Measure thickness of ladder.
- If height of ladder hook is not equal to measured ladder thickness, remove the flanged lock nuts on the rear of the ladder hook and reposition ladder hook to match ladder height.
- Tighten 5/16" flanged lock nuts until nut just completely past stud end threads. **Be sure the two nuts are securely threaded on ladder hook studs.**

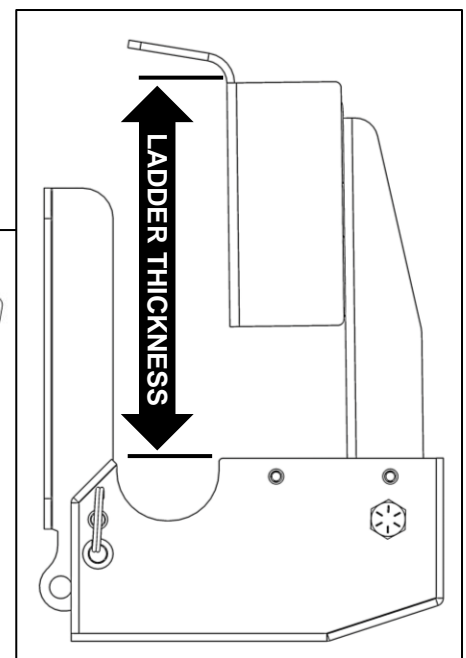
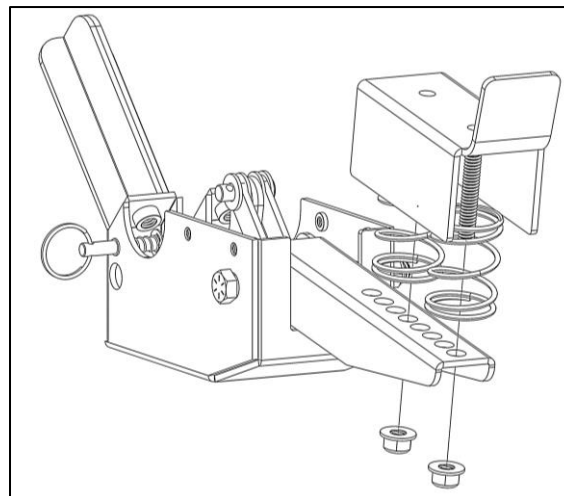

Step 4 – Attach Front Clamp

- Position the clamp mechanism in desired position on the rack so the clamp is between two ladder rungs. Be sure handle is towards outside of vehicle.
- Using the 5/16" x 3/4" hex head bolts, 5/16" lock washers, and 5/16" flat washers, **LOOSELY** bolt the front clamp to the swing arm assembly. **DO NOT tighten.**

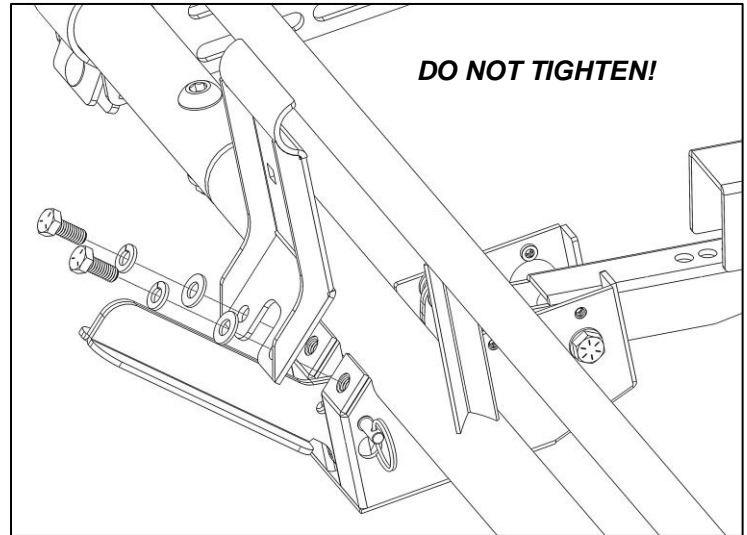
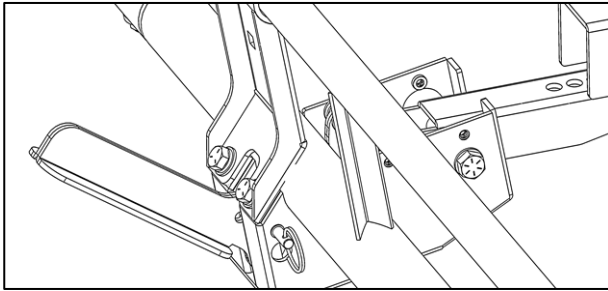

Step 5 – Attach Rear Clamp

- Cut the UHMW tape strip into two almost square strips.
- Apply strips onto lower bar where rear clamp will come into contact.
- Squeeze top and bottom tubes on rack between front and rear clamps.
- Using two 5/16" x 3/4" carriage bolts and two 5/16" lock nuts, **LOOSELY** bolt the front and back clamps together. **DO NOT tighten.**
- **LOOSELY** secure rear clamp to swing arm using the four #10 x 1/2" pan head screws. **DO NOT tighten.**

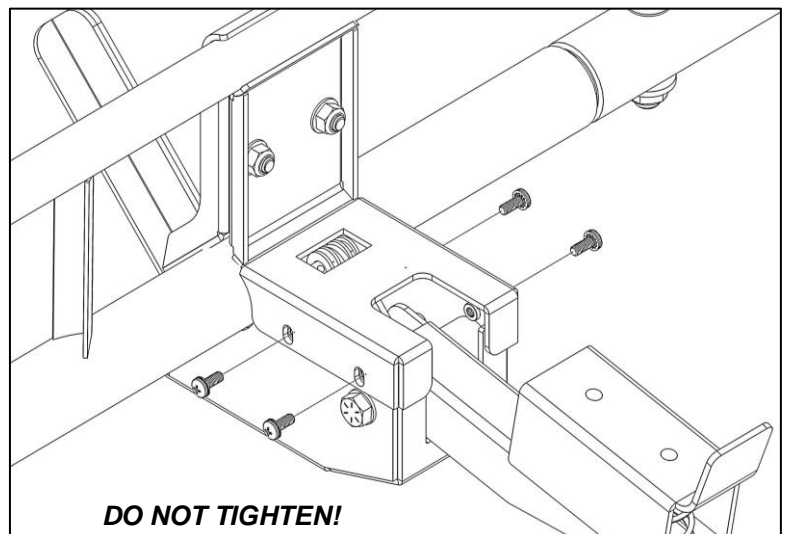
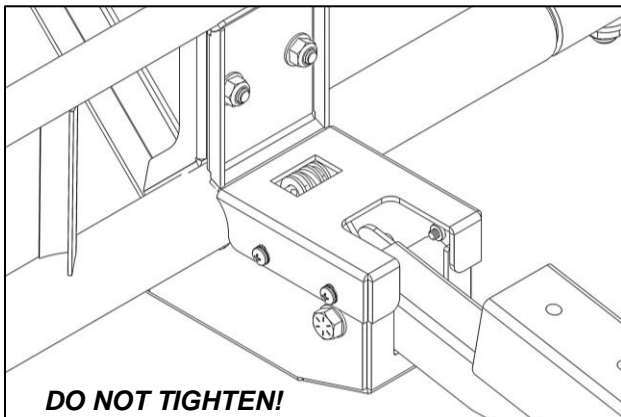
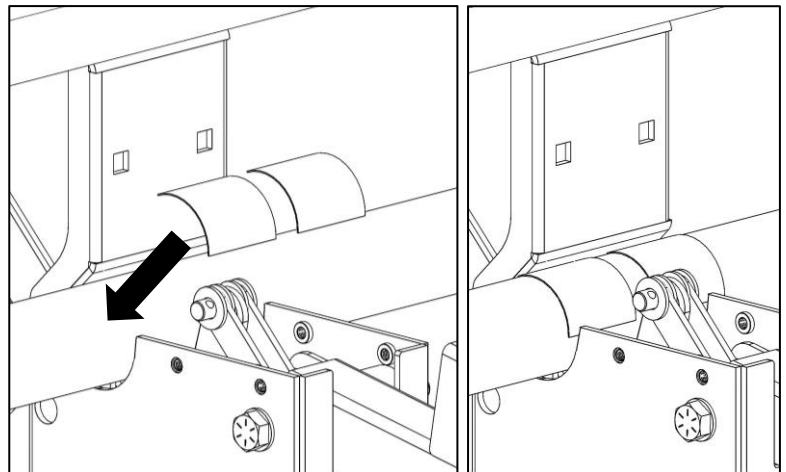

- **TIGHTEN 5/16" hex head bolts from Step 3, THEN tighten remaining hardware.**

Step 6 – Adjust for Ladder

- Set ladder onto rack, firmly against side channel.
- Pull pin to release and then clamp ladder in position.

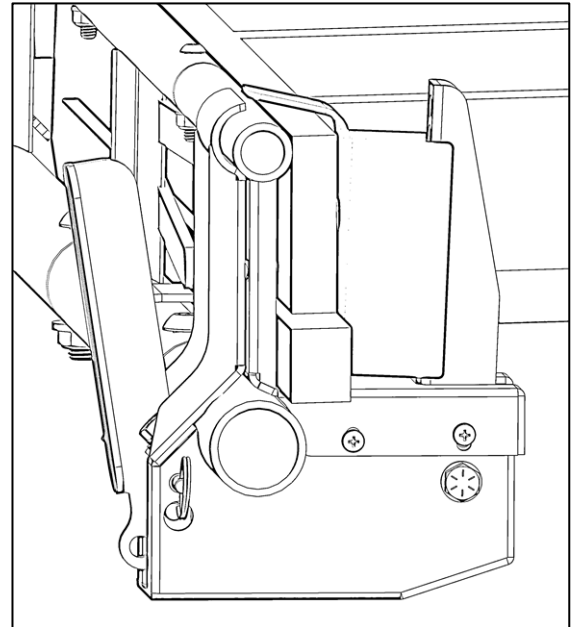
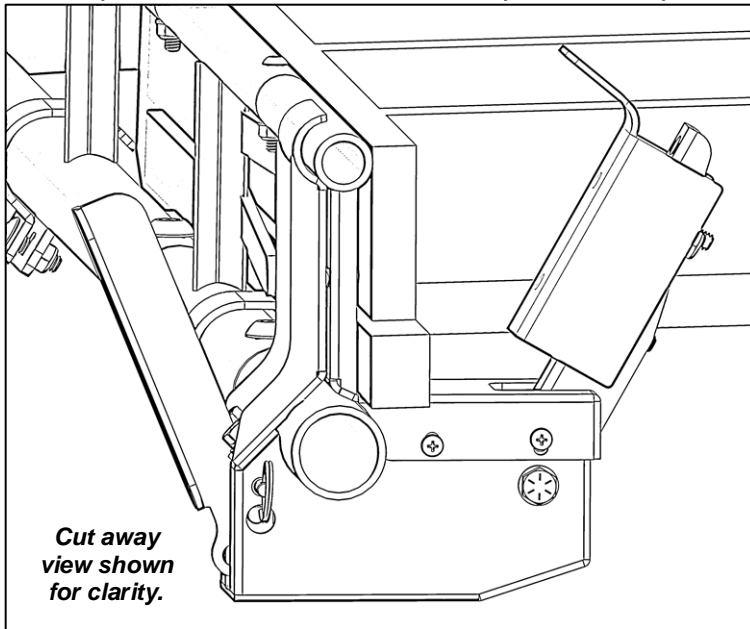

- If ladder is thicker or the ladder hook is not clamping properly, adjust the ladder hook by removing flanged lock nuts on rear of ladder hook and then repositioning ladder hook to fit the ladder thickness.
- Be sure the two nuts are securely threaded onto ladder hook studs.

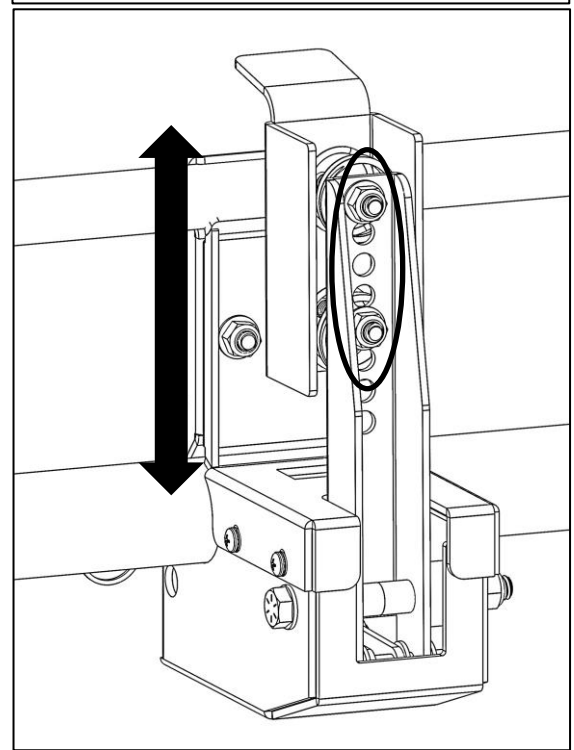
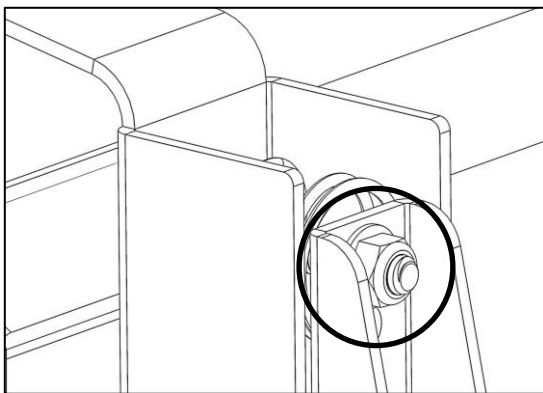

Always ensure lock pin is in lock position and clamp is properly adjusted before transporting any ladder.

GO BACK AND TIGHTEN ALL HARDWARE.

INSTALLATION AND ASSEMBLY ARE COMPLETE.