

Holman

Instruction Guide

40451

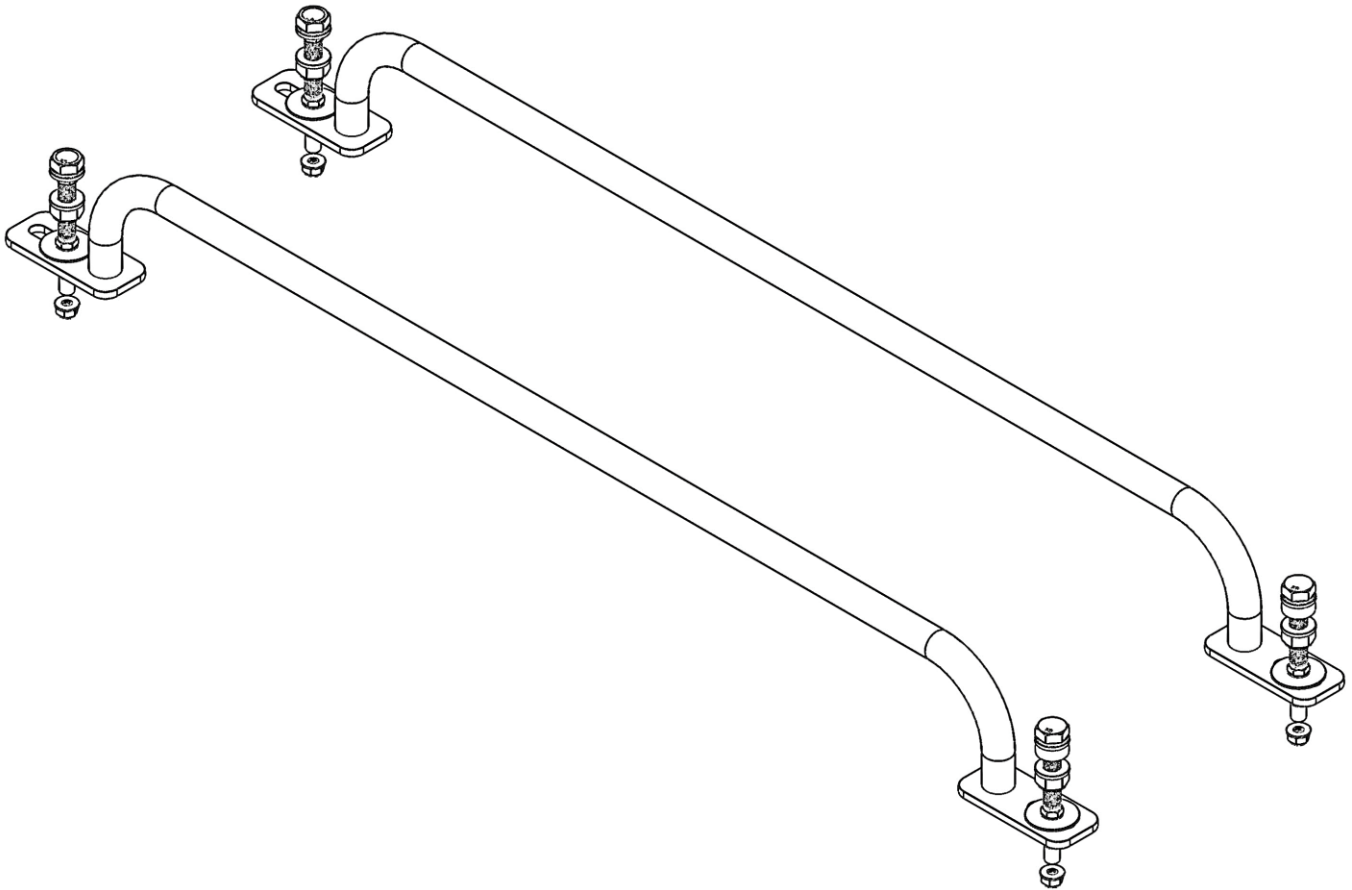

Holman
Rancho Cordova, CA 95742
800-343-7486
InstallationSupport@Holman.com

PLEASE READ ALL INSTRUCTIONS AND WARNINGS PRIOR TO ASSEMBLING, INSTALLING, AND USING THIS PRODUCT.

Warning



Always check for wires, fuel tanks and lines, brake lines and other important vehicle functionality items prior to drilling and installing all products.

Table of Contents

Tools Needed 1

Before You Begin 1

Parts List..... 2

Hardware 2

Hardware Continued..... 3

Step 1 – Locate Mount Location 3

Step 2A – Transit..... 4

Step 2B – Sprinter 5

Step 2C – GM Van 5

Step 2D – Shelf/Partition 5

Step 3 – Install Plus Nuts..... 6

Step 4 – Attach Grab Handle Using Plus Nuts 6

Tools Needed

| | |
|-------------------------------|-------------------------------------|
| 7/16" Socket and Wrench | Drill |
| 13mm Socket and Socket Wrench | 25/64", 5/16" Drill Bit |
| 17mm Socket and Wrench | Drill Bit Stop Collar |
| 9/16" Wrench | Plus Nut Installation Tool (P9902)* |

** Sold Separately.*



Before You Begin

- Read all instructions prior to assembling or installing any Holman product.
- **Always locate your installation locations prior to performing any work.**
- **ENSURE SAFETY WHILE INSTALLING OR DRILLING INTO VEHICLE.**
- **Plus Nut Installation Tool Kit (P9902) is not included and must be purchased separately.**

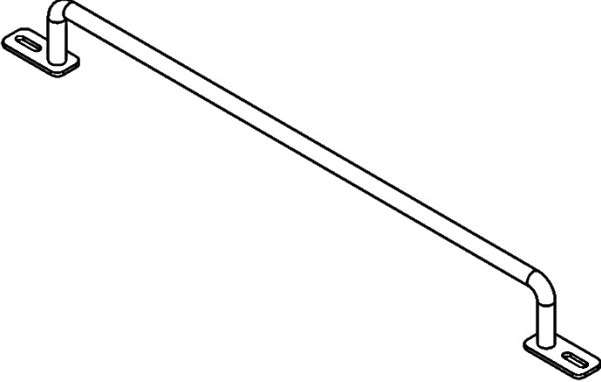

Parts List

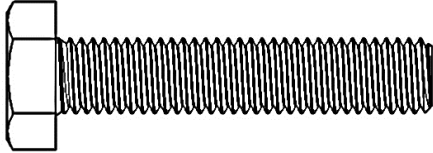
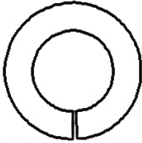
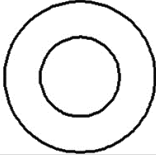
| NO. | ITEM | PART NUMBER | DESCRIPTION | QTY. |
|-----|---|-------------|-------------------|------|
| 1 |  | 101352 | LARGE GRAB HANDLE | 2 |
| 2 | | 18-40451 | HARDWARE KIT | 1 |

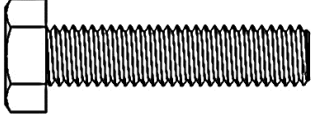
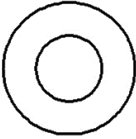
Hardware

| ITEM | HARDWARE TO SCALE | PART NUMBER | DESCRIPTION | QTY. |
|------|---|-----------------|---------------------------------|------|
| 1 |  | 91280A642 | M10-1.5 x 50MM HEX HEAD BOLT | 4 |
| 2 |  | ML6400000ZY0000 | M10 Split Lock Washer | 4 |
| 3 |  | 11552366 | M10 FLAT WASHER | 8 |
| 4 |  | 11551260 | M10 NYLOCK NUT | 4 |
| 5 |  | 0158989 | M8-1.25 X 35MM HEX HEAD BOLT | 2 |
| 6 |  | 33080 | 5/16" WASHER | 2 |

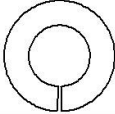
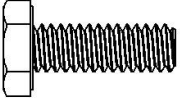
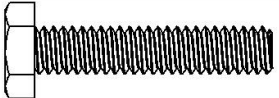
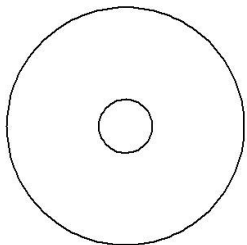
Hardware Continued

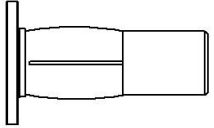
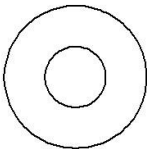
| ITEM | HARDWARE TO SCALE | PART NUMBER | DESCRIPTION | QTY. |
|------|---|-------------|---------------------------------------|------|
| 7 |  | 1133620 | 5/16" LOCKING WASHER | 2 |
| 8 |  | 13003 | 1/4"-20 X 3/4" HEAD HEAD BOLT | 4 |
| 9 |  | 13800 | 1/4"-20 x 1-1/4" HEX HEAD BOLT | 4 |
| 10 |  | 33208 | 1/4" FENDER WASHER | 4 |
| 11 |  | 33618 | 1/4" LOCK WASHER | 4 |
| 12 |  | 0167030 | 1/4"-20 FLANGED LOCK NUT | 4 |
| 13 |  | 93483A691 | 1/4"-20 Plus Nut | 4 |
| 14 |  | - | 25/64" ID X 1" OD X 3/8" NYLON SPACER | 2 |

Step 1 – Locate Mount Location

- Grab handle can be installed in rear of Transit, and Sprinter using existing holes shown below.

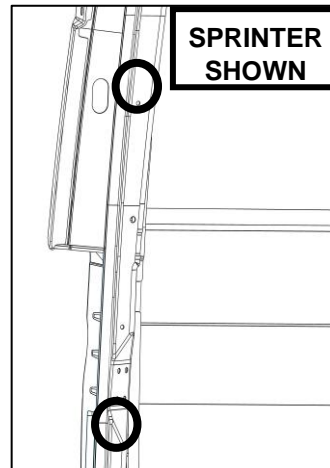
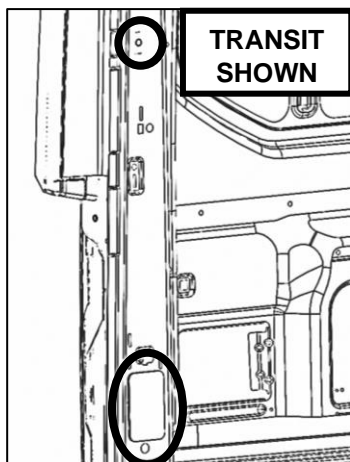

- Grab handle can also be mounted to shelf end panels, van partitions and GM vans by drilling mounting holes. Some sample installations shown below.

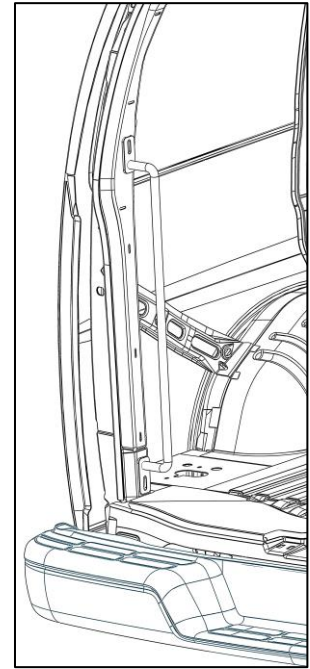
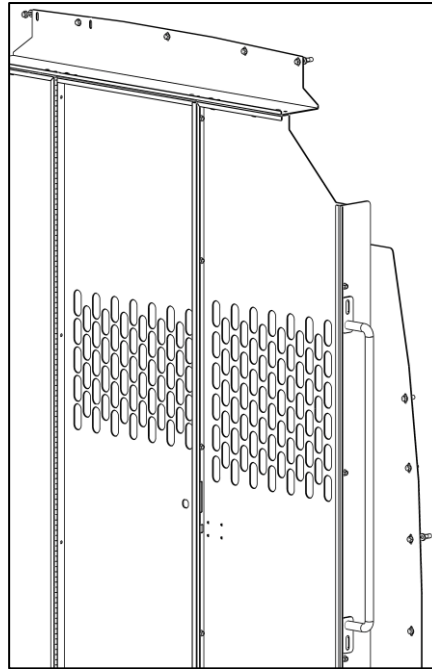
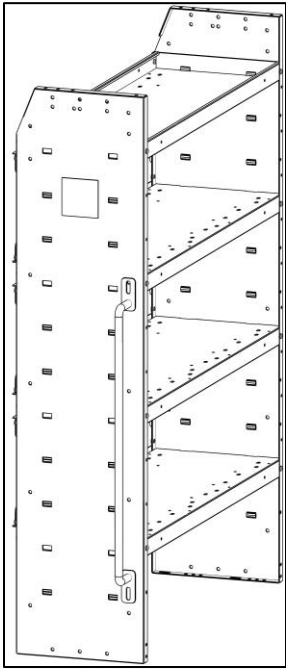

Step 2A – Transit

- Using a M10 flat washer, a M10 lock washer, and a M10 x 50mm hex head, bolt top of grab handle to the threaded emboss.
- Follow the orientation and order of hardware as shown.
- Locate black rectangular cover near the bottom of the D-pillar.
- Remove cover.
- Swing bottom of handle so that it lines up with the accessible hole below previously removed black cover.
- Bolt through the reinforced hole using a M10 x 50mm hex head screw, a M10 lock washer, two M10 flat washers, a 1" OD x 3/8" nylon spacer, and a M10 lock nut.
- To reach the lock nut, you must access it through the square hole where the black cover was removed.
- Re-install the previously removed cover.

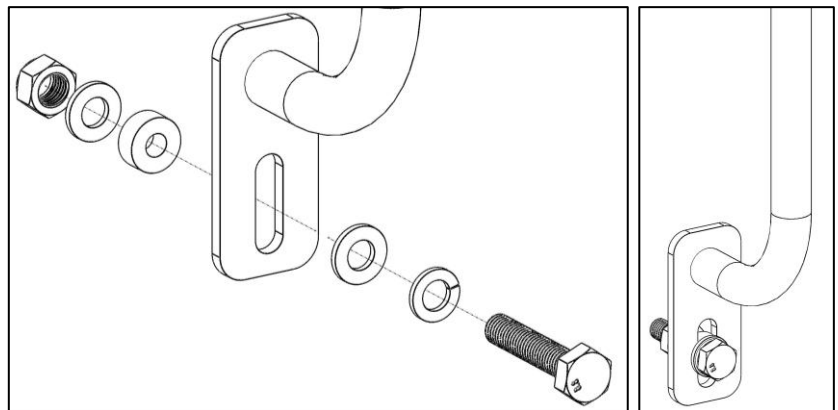
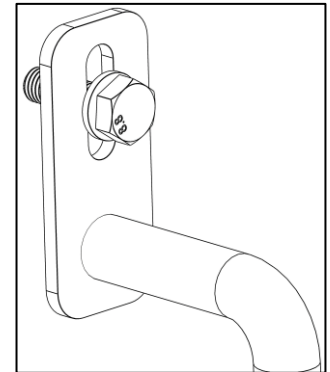
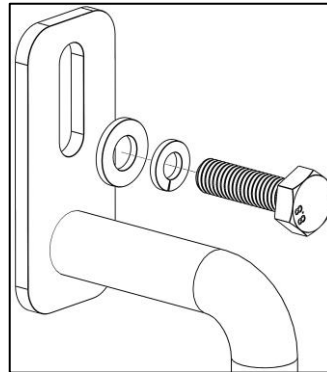

Step 2B – Sprinter

- Using a 5/16" flat washer, a 5/16" lock washer, and a M8 x 35mm hex head, bolt top of grab handle to the threaded emboss.
- Follow the orientation and order of hardware as shown.

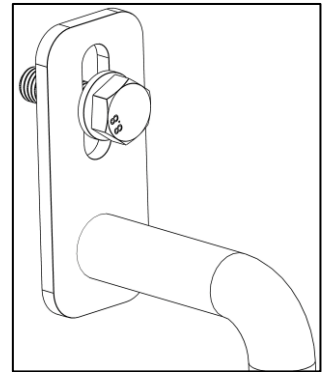
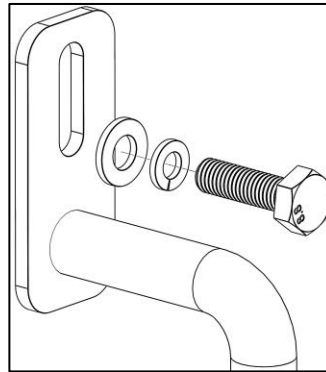

- Swing bottom of handle so that it lines up with existing hole and mark hole to be drilled for plus nut installation.
- Remove or swing grab handle out of the way.
- Proceed to Step 3

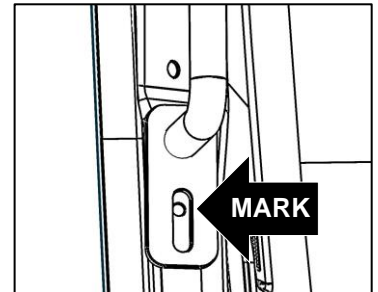

Step 2C – GM Van

- Locate desired mount location at rear of van.
- Mark top and bottom holes to be drilled for plus nut installation.
- Proceed to Step 3

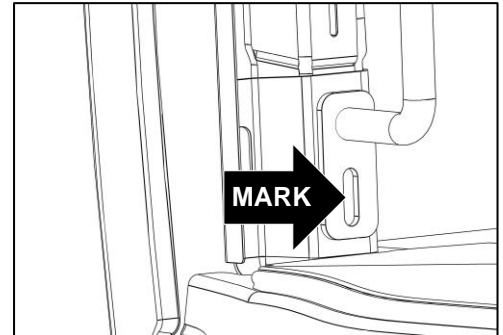
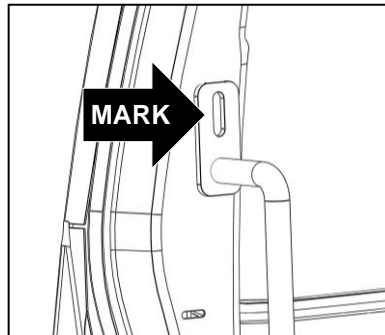

Step 2D – Shelf/Partition

- Locate desired mount location on shelf or partition.

NOTE: Some locations may allow use of existing holes.

- Mark top and bottom holes.
- Drill top and bottom holes using 5/16" drill bit.
- Using 1/4" x 3/4" hex head bolt, 1/4" lock washer, 1/4" fender washer, and 1/4" flanged lock nut bolt through grab handle into previously drilled 5/16" hole.

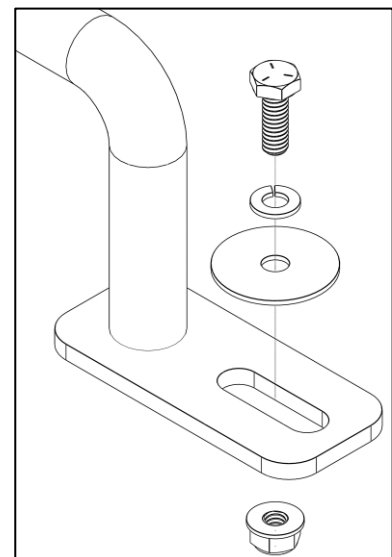

Step 3 – Install Plus Nuts



DO NOT drill beyond depth of floor or upper installation surface. Always check for wires, fuel tanks and lines, brake lines and other important vehicle functionality items prior to drilling and installing all products.

- At each marked location, drill hole using 25/64" drill bit and appropriate sized drill-bit stop collar. If 25/64" drill bit is not available, a 3/8" drill bit can be used, although it may be necessary to tap in the plus nuts.
- Insert 1/4" x 2-1/4" hex head bolt through 1/4" flat washer and plus nut installation tool, and then screw bolt into plus nut. Knurled end of plus nut tool must be directed away from bolt head and contacting plus nut.
- Insert plus nut into hole with plus nut tool attached.
- Using the 9/16" box wrench, hold the plus nut tool stationary and then tighten hex head bolt until plus nut is tightly gripping and does not spin when hex bolt is loosened.
- DO NOT overtighten plus nut.
- Using the 9/16" box wrench, hold the plus nut tool stationary to remove the 1/4" hex head bolt.

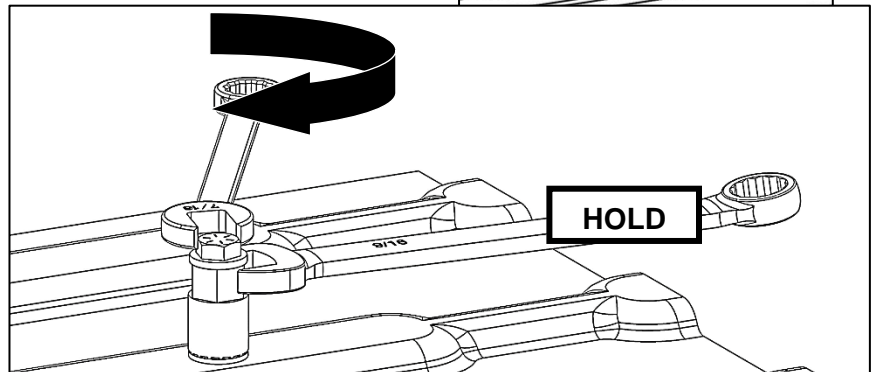
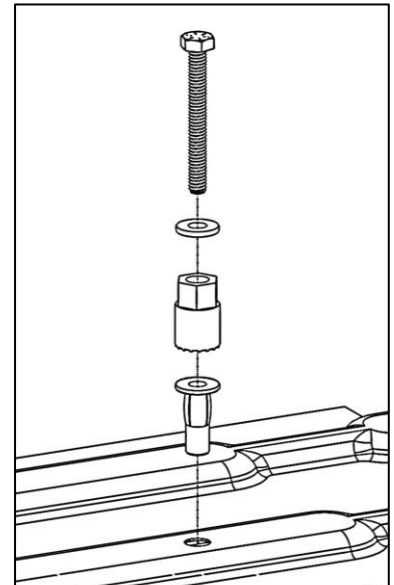

Step 4 – Attach Grab Handle Using Plus Nuts

- Using 1/4" x 1-1/4" hex head bolt, 1/4" lock washer, and 1/4" fender washer, bolt through grab handle into previously installed plus nut.

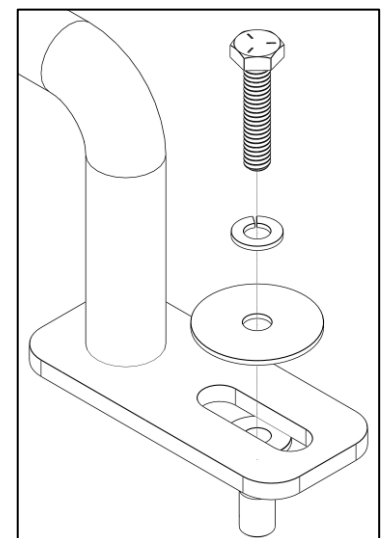

GO BACK AND TIGHTEN ALL HARDWARE.
INSTALLATION IS COMPLETE.