

Holman

Instruction Guide 40476PE – 40476PL

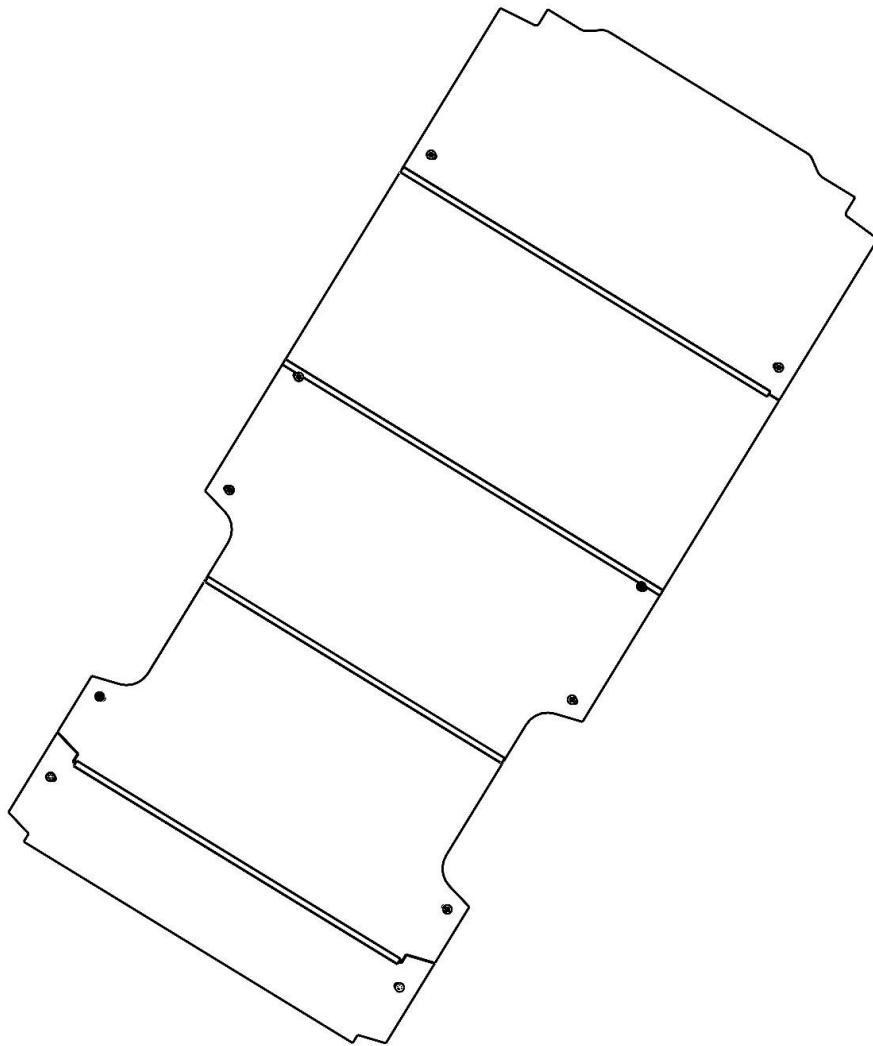

Holman
Rancho Cordova, CA 95742
800-343-7486
InstallationSupport@holman.com

PLEASE READ ALL INSTRUCTIONS AND WARNINGS PRIOR TO ASSEMBLING, INSTALLING, AND USING THIS PRODUCT.

Warning



Always check for wires, fuel tanks and lines, brake lines and other important vehicle functionality items prior to drilling and installing all products.



DO NOT USE IMPACT DRIVER TO INSTALL HARDWARE INTO FLOORING MATERIAL. SET DRILL DRIVER TO LOWEST SETTING AND INCREASE TORQUE ONLY AS NEEDED.

Tools Needed

15mm Sockets and Socket Wrench	T40 Torx Bit
--------------------------------	--------------

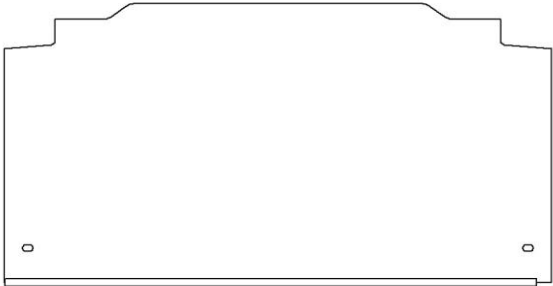

Table of Contents

Before You Begin	1
40476PL & 40476PE Parts List	2
18-40476PL Floor Hardware (ALL FLOOR KITS)	3
18-40476PE Floor Extension Hardware (40476PE ONLY).....	3
Step 1 – Remove Factory D-Rings	4
Step 2 – Position Floor	4
Step 3 – Install D-ring Bolts	4
Attaching Accessories to Floor	5
Install Plus Nuts.....	5

Before You Begin

- Read all instructions prior to assembling or installing product.
- **Always locate your installation locations prior to performing any work.**
- **ENSURE SAFETY WHILE INSTALLING OR DRILLING INTO VEHICLE.**
- Any previously installed flooring must be removed prior to installing Holman flooring.
- Floor must be assembled in vehicle.
- 40475HW hardware kit may be necessary to install some accessories to Holman flooring. (40475HW sold separately).
- 40477P threshold kit must be installed when installing Holman flooring. (40477P sold separately).

40476PL & 40476PE Parts List

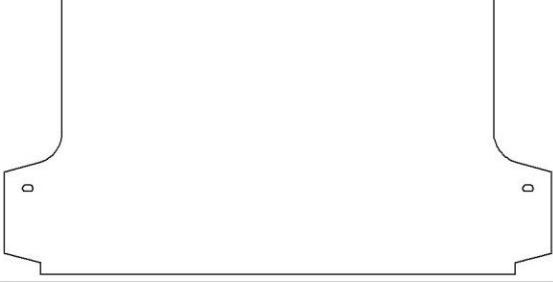
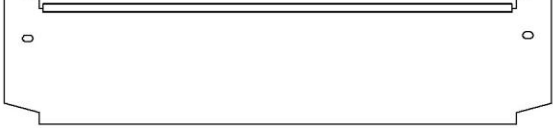
NO.	ITEM	PART NUMBER	DESCRIPTION	QTY.
1		101839	PROMASTER 159" FRONT FLOOR PAN	1
2		101840	PROMASTER 159" CENTER FRONT FLOOR PAN	1
3		102226	PROMASTER 159" CENTER REAR FLOOR PAN	1
4		101638	PROMASTER 159" WB REAR FLOOR PAN	1
5		101841	PROMASTER 159" REAR FLOOR EXTENSION	1
6		18-40476PL	HARDWARE KIT	1
7		18-40476PE	FLOOR EXTENSION HARDWARE KIT	1

18-40476PL Floor Hardware (ALL FLOOR KITS)

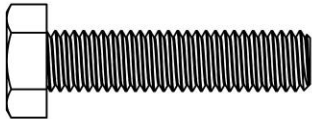
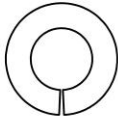
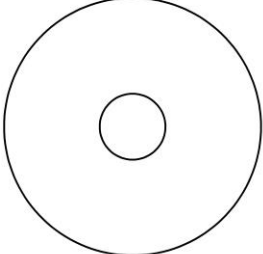
ITEM	HARDWARE TO SCALE	PART NUMBER	DESCRIPTION	QTY.
1		0158989	M8-1.25 X 35MM HEX HEAD BOLT	8
2		1133620	5/16" LOCKING WASHER	8
3		33216	5/16" Fender Washer	8

18-40476PE Floor Extension Hardware (40476PE ONLY)

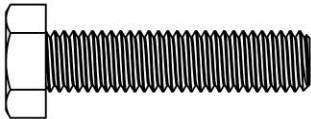
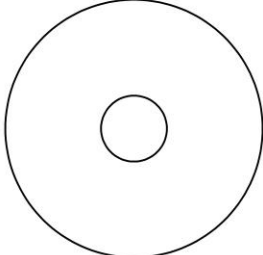
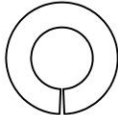
ITEM	HARDWARE TO SCALE	PART NUMBER	DESCRIPTION	QTY.
1		0158989	M8-1.25 X 35MM HEX HEAD BOLT	2
2		33216	5/16" Fender Washer	2
3		1133620	5/16" LOCKING WASHER	2

Step 1 – Remove Factory D-Rings

- Using T40 Torx bit remove eight OEM D-Rings for ProMaster 159" wheelbase and 10 OEM D-Rings for ProMaster 159" Extended wheelbase. **Be sure to save D-Rings if re-installation is desired.**

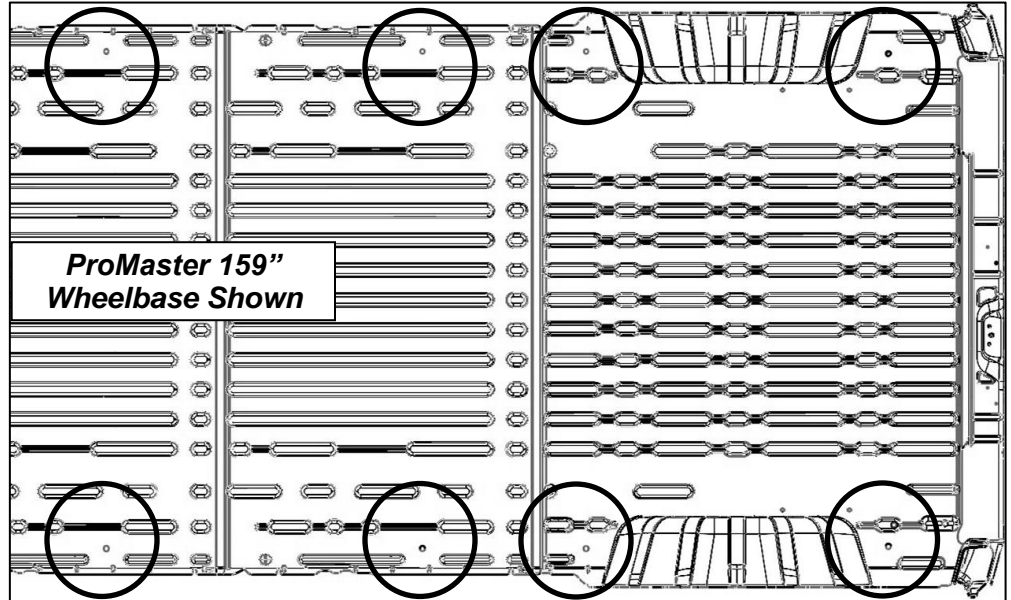

Step 2 – Position Floor

Floor must be assembled in vehicle.

- Set front panel in position.
- Press center front panel into aluminum extrusion of front panel.
- Press center rear panel into aluminum extrusion of center front panel.
- Press rear panel into aluminum extrusion of center rear panel.

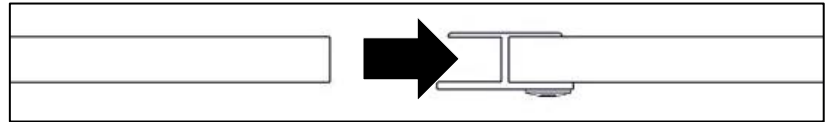

Note: For ProMaster 159" Extended wheelbase press extension panel onto rear panel.

Step 3 – Install D-ring Bolts

Note: Floor must be secured using supplied hardware at OEM D-ring locations circled above even if it is not desired to re-install OEM D-Rings.

- If re-installing OEM D-Rings remove, OEM bolt from D-Ring.
- Using M8 x 35mm hex head bolt, 5/16" lock washer, OEM D-Ring (if desired) and 5/16" fender washer, bolt through Holman floor at OEM D-Ring locations.

**GO BACK AND TIGHTEN ALL
HARDWARE.
INSTALLATION AND ASSEMBLY ARE
COMPLETE.**

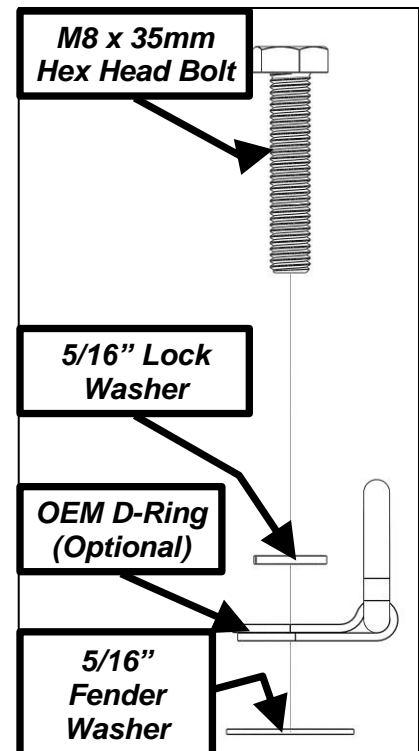

Attaching Accessories to Floor

Preferred Method

Note: Spacers are typically included with Holman accessories.

- Determine installation location.
- Drill a 1-1/8" hole through Holman floor in each mount location. **Be sure not to drill through metal van floor with 1-1/8" drill bit.**
- In the center of each hole, install a plus nut using the instructions below.
- Use 1" x 3/8" plastic spacer (Holman p/n 40501) in each hole as needed to attach accessories to steel van floor.

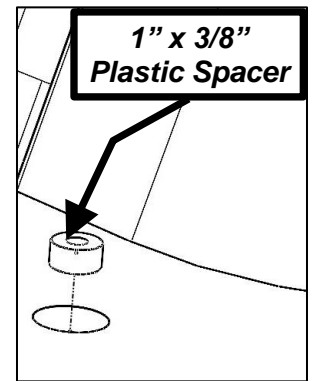

Alternate Method



This method should only be used when drilling into the van floor is not allowable. This method should not be used for top heavy accessories without additional support or excessively heavy items.

- Determine installation location.
- Drill a 5/16" hole through floor in each installation.
- Use 1/4" hardware and 1/4" t-nut threaded inserts* to install accessories to floor.

** T-nut threaded inserts sold separately in 40475HW hardware kit.*

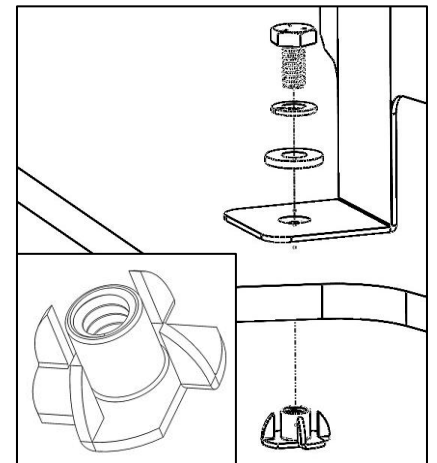

Install Plus Nuts



DO NOT drill beyond depth of floor or upper installation surface. Always check for wires, fuel tanks and lines, brake lines and other important vehicle functionality items prior to drilling and installing all products.

- At each marked location, drill hole using 25/64" drill bit and appropriate sized drill-bit stop collar. If 25/64" drill bit is not available, a 3/8" drill bit can be used, although it may be necessary to tap in the plus nuts.
- Insert 1/4" x 2-1/4" hex head bolt through 1/4" flat washer and plus nut installation tool, and then screw bolt into plus nut. **Knurled end of plus nut tool must be directed away from bolt head and contacting plus nut.**
- Insert plus nut into hole with plus nut tool attached.
- Using the 9/16" box wrench, hold the plus nut tool stationary and then tighten hex head bolt until plus nut is tightly gripping and does not spin when hex bolt is loosened.
- DO NOT overtighten plus nut.
- Using the 9/16" box wrench, hold the plus nut tool stationary to remove the 1/4" hex head bolt.

