

Holman

Installation Guide 40815

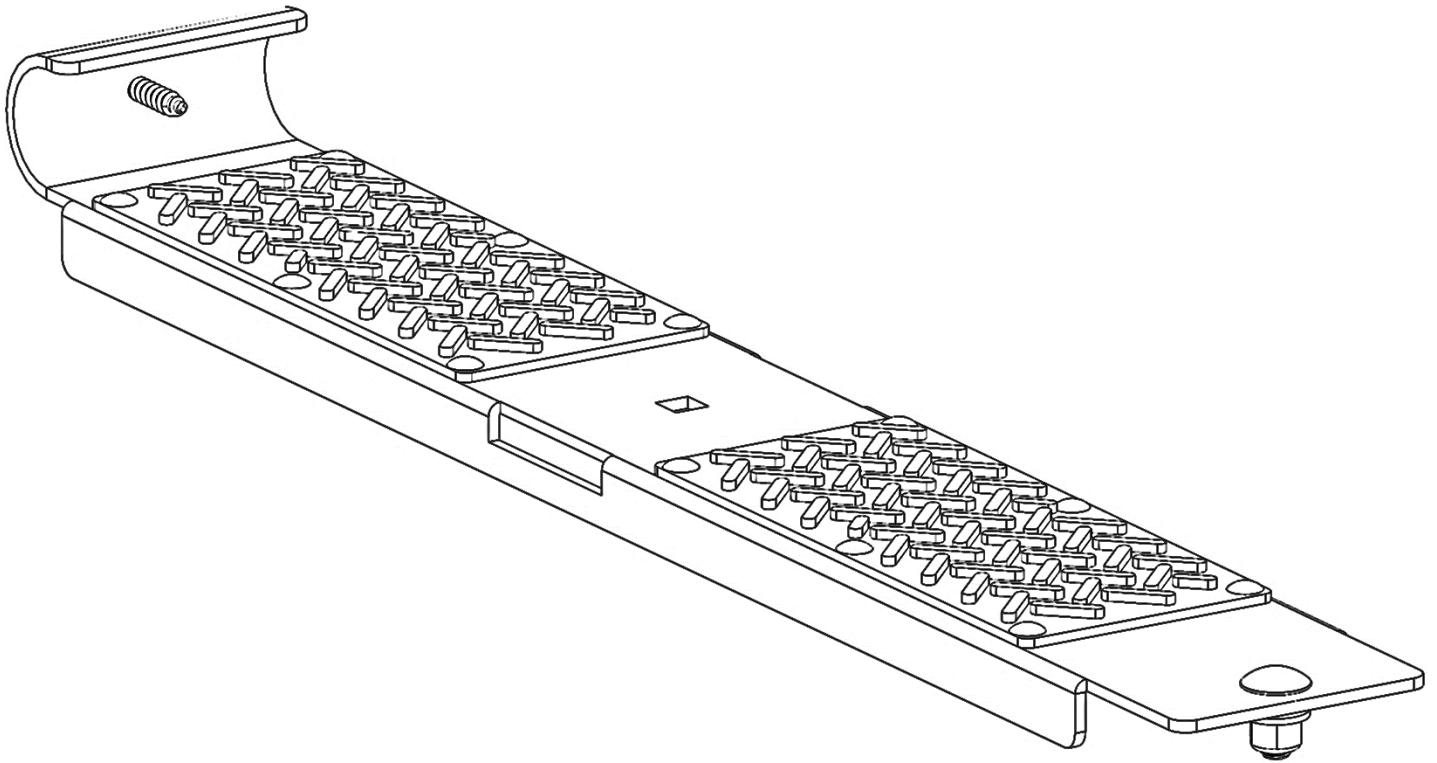

Holman
Rancho Cordova, CA 95742
800-343-7486
InstallationSupport@holman.com

PLEASE READ ALL INSTRUCTIONS AND WARNINGS PRIOR TO ASSEMBLING, INSTALLING, AND USING THIS PRODUCT.

Warning



Always check for wires, fuel tanks and lines, brake lines and other important vehicle functionality items prior to drilling and installing all products.



DO NOT EXCEED MANUFACTURERS WEIGHT CAPACITY FOR ROOF.

Tools Needed

1/2" Socket and Wrench	3/8" Driver Bit
11/32" Drill Bit	Drill Driver

Table of Contents

Before You Begin 1

Parts List..... 1

Hardware 2

Step 1 – Re-Locate Ladder Stop 2

Step 2 – Stepladder Bracket Installation..... 3

Step 3A – No-Drill Installation Method 4

Step 3B – Drilling Required Installation Method 5



Before You Begin

- Read all instructions prior to installing any Holman rack or accessory.
- Associated Clamp and Lock ladder rack must be assembled prior to installation of this accessory.
- For adjustment instructions, refer to the *Clamp N Lock Ladder Adjustment Instructions*.
- **ENSURE SAFETY WHILE INSTALLING ONTO VEHICLE.**

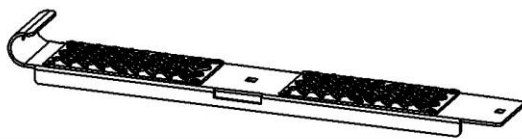
Parts List

NO.	ITEM	PART NUMBER	DESCRIPTION	QTY.
1		101779	STEPLADDER BRACKET W/ PADS	1
2		18-00532	40815 HARDWARE KIT	1

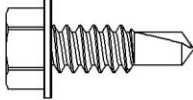
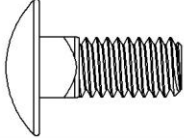
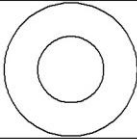
Hardware

ITEM	HARDWARE TO SCALE	PART NUMBER	DESCRIPTION	QTY.
1		31960	1/4"-14 x 1" SELF TAPPING SCREW	1
2		21810	5/16"-18 X 3/4" CARRIAGE BOLT	1
3		90126A030	5/16" FLAT WASHER	1
4		0169777	5/16"-18 LOCK NUT	1

Step 1 – Re-Locate Ladder Stop

- Remove ladder stop from the original location.

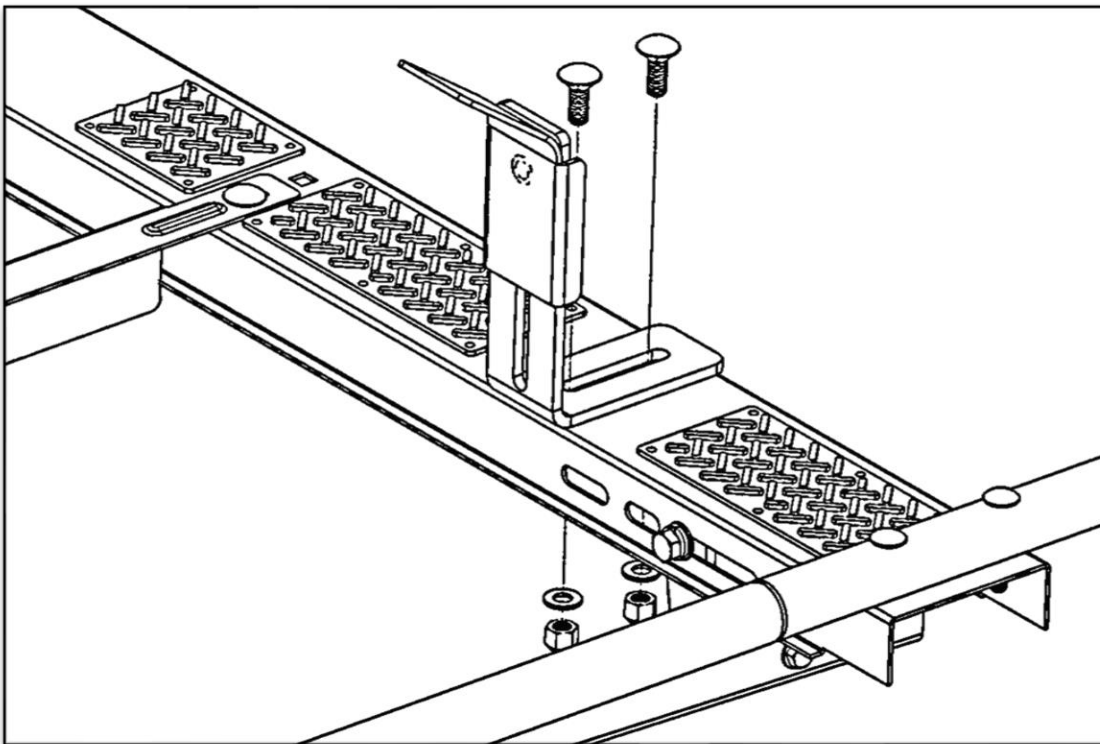

- Bolt ladder stop to the stepladder bracket. Depending on the ladder being used, the ladder stop may be rotated to provide better clamping of the ladder.
- Snug tighten but allow for movement.

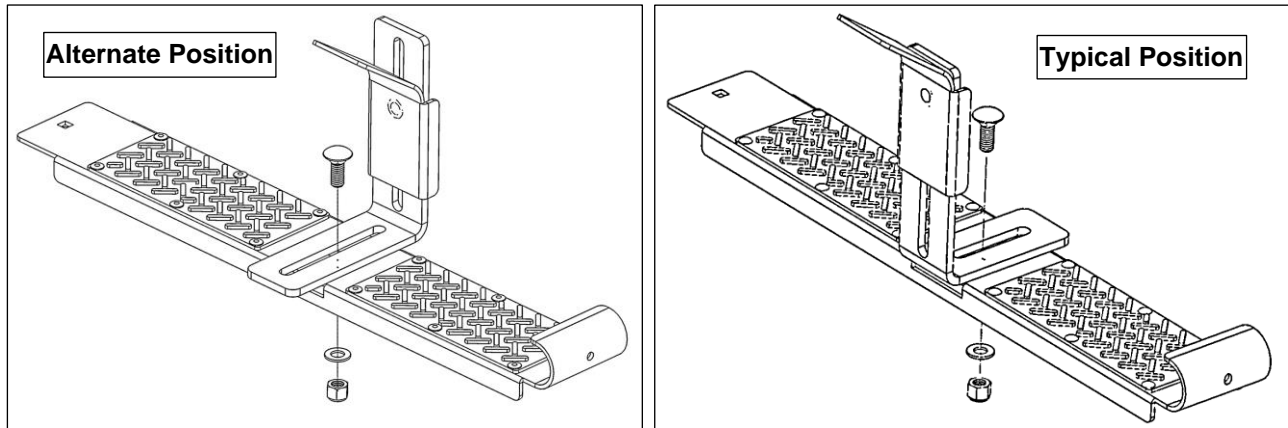

Step 2 – Stepladder Bracket Installation

Recent updates to the clamp and lock L-brackets have added no-drill options for installing the stepladder bracket. Verify whether or not your rack has holes available in the L-bracket for the no-drill option.

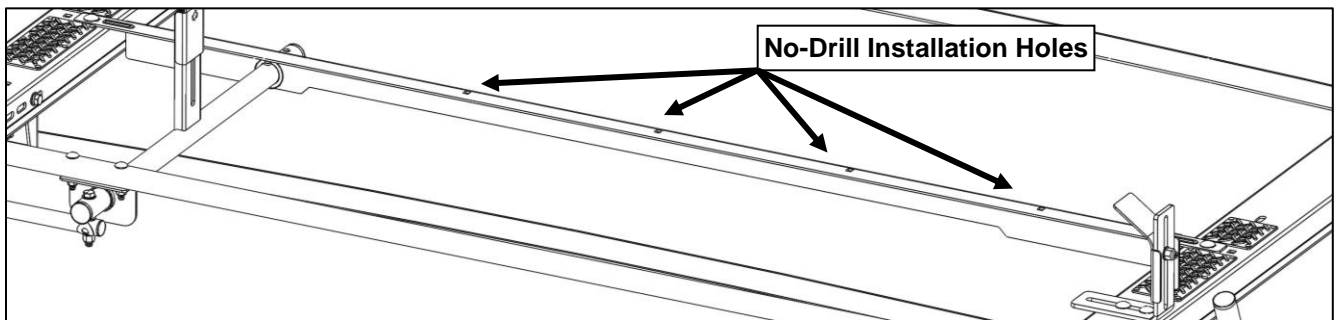

- Position the stepladder bracket on the ladder rack so the ladder is squeezed between the two ladder clamps as shown below.
- Double check that the position is correct.

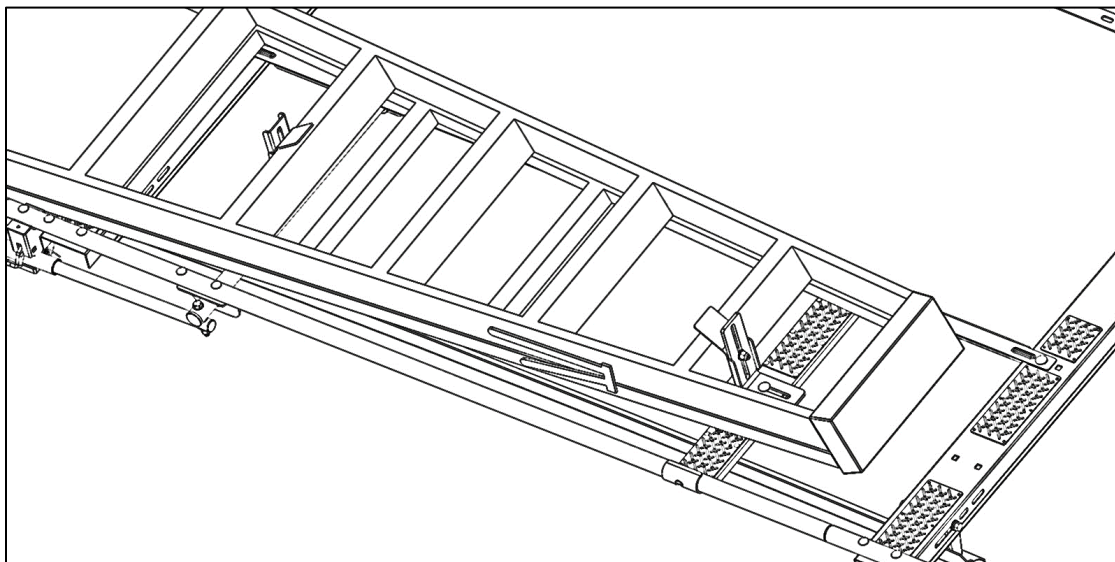

Step 3A – No-Drill Installation Method

- Make note of the hole in L-bracket closest to the hole in stepladder bracket.
- Remove ladder.
- Using a 5/16" x 3/4" carriage bolt, 5/16" washer, and 5/16" lock nut, **LOOSELY** bolt the stepladder bracket to the L-bracket.

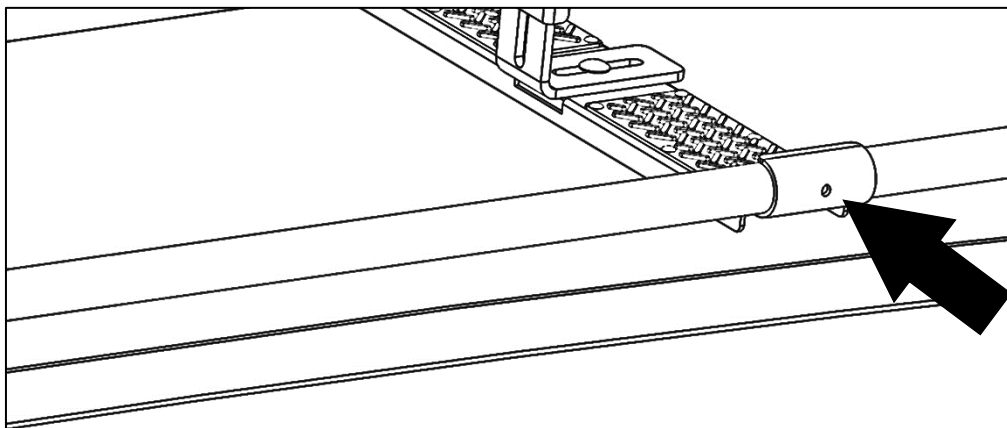
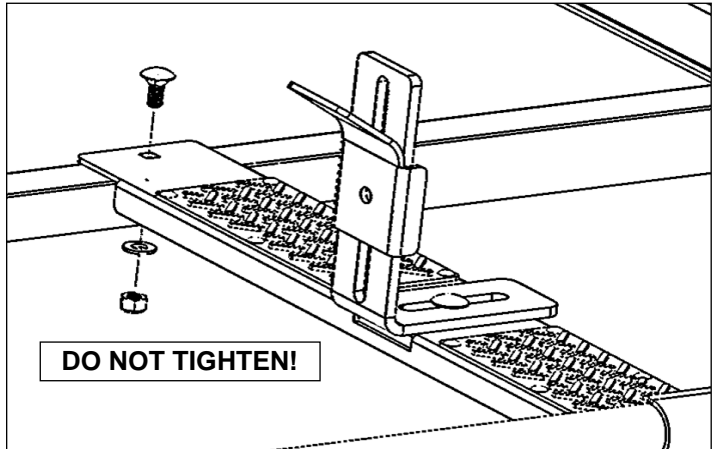

- If using drill driver, set drill clutch for the lowest setting and increase torque only as needed.
- Using the 1/4" x 1" self drilling screw, fasten the stepladder bracket to the tube.
- Tighten all hardware.

⚠ Be sure to adjust ladder hooks per the Ladder Hook Adjustment Guide prior to use or transport.

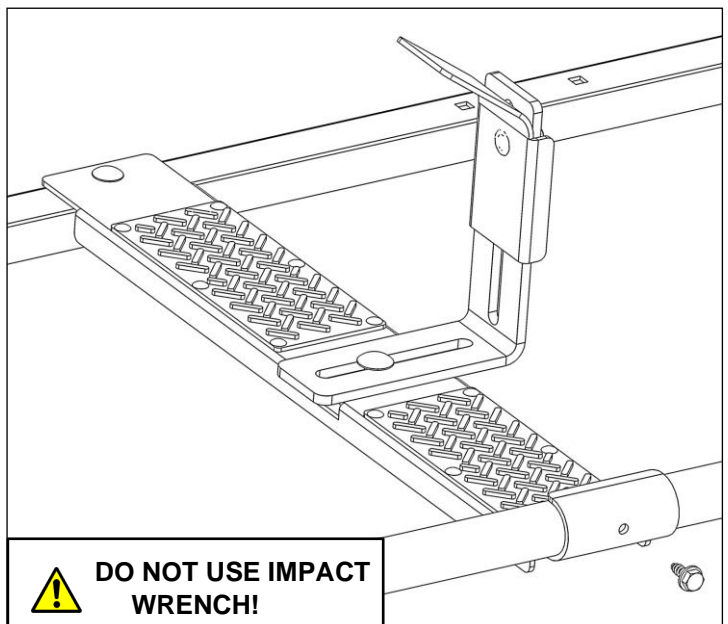

Step 3B – Drilling Required Installation Method

- With the ladder in place, mark the position of the hole, in the round end of the stepladder bracket, onto the round support tube.
- Mark the position of the square hole on ladder rack cross support L-bracket
- Remove ladder.

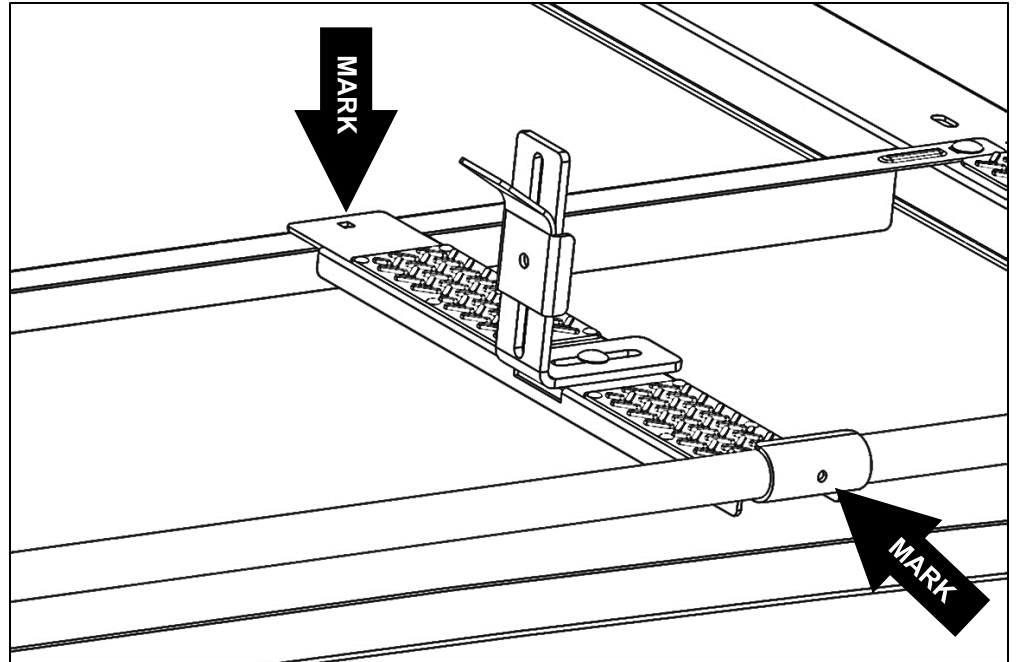

- Drill through ladder rack cross support angle bracket using an 11/32" drill bit.

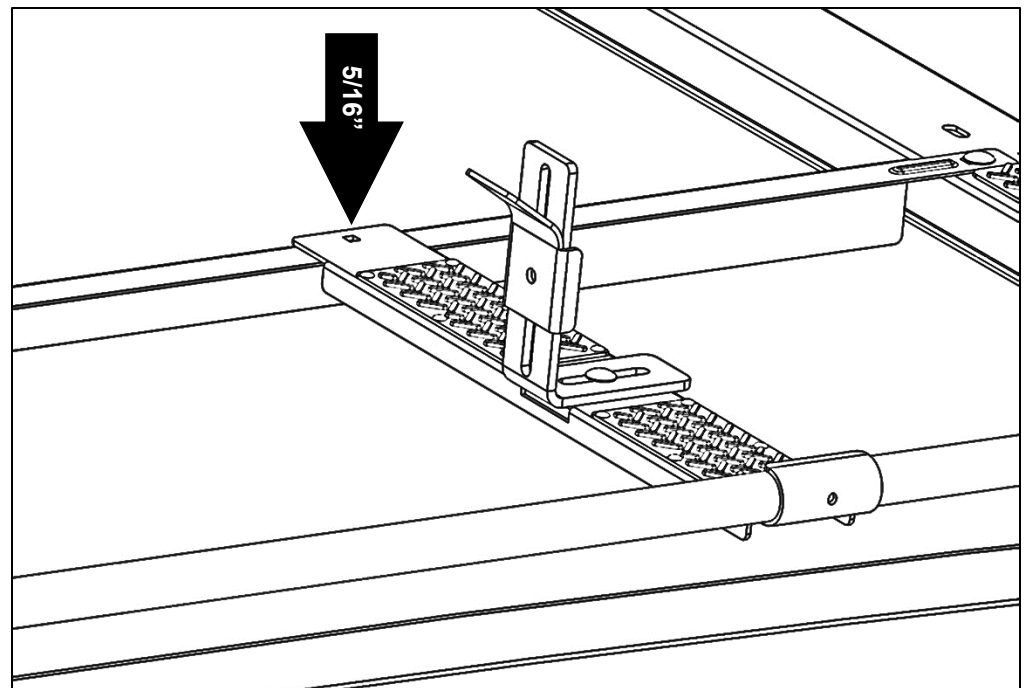

- **LOOSELY** bolt stepladder bracket to the cross support angle bracket using one 5/16" x 3/4" carriage bolt, 5/16" flat washer, and 5/16" lock nut.

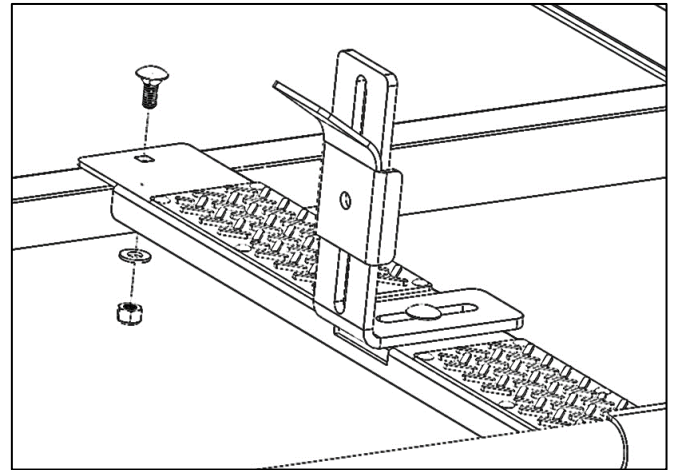

- If using drill driver, set drill clutch for the lowest setting and increase torque only as needed.
- Fasten the stepladder bracket to the tube using the 1/4" x 1" sheet metal screw.

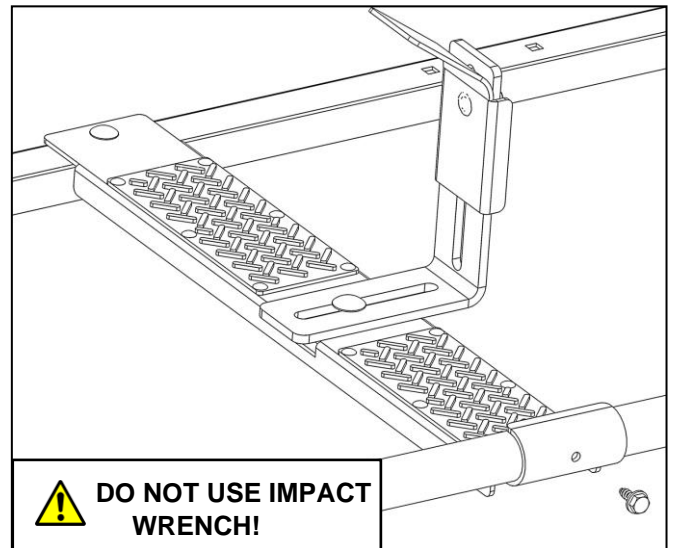

- Tighten all hardware.



Be sure to adjust ladder hooks per the Ladder Hook Adjustment Guide prior to use or transport.

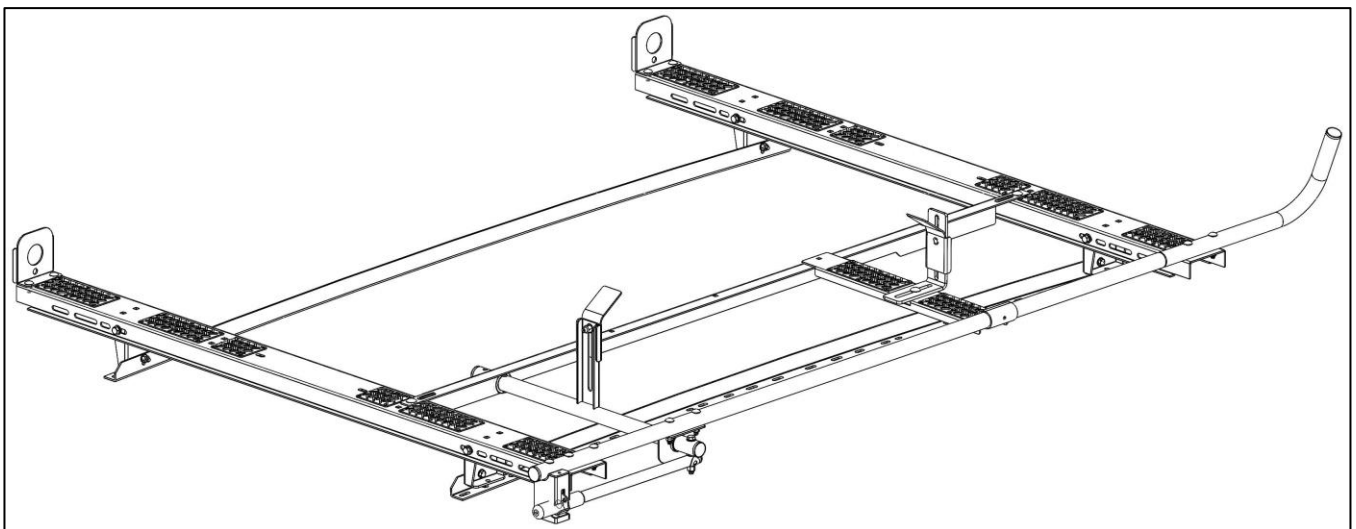

GO BACK AND TIGHTEN ALL HARDWARE.

YOUR INSTALLATION IS NOW COMPLETE.