

# Holman

---

## Instruction Guide 4A91H

---

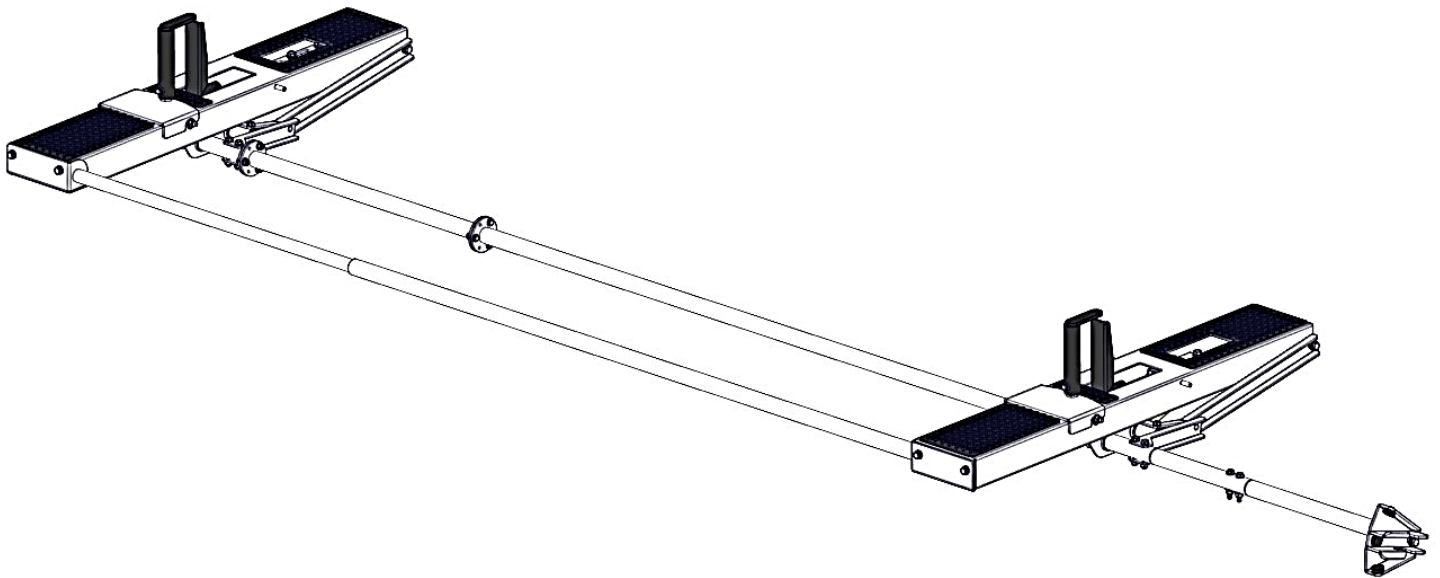

---

Holman  
Rancho Cordova, CA 95742  
800-343-7486  
[InstallationSupport@Holman.com](mailto:InstallationSupport@Holman.com)

---

**PLEASE READ ALL INSTRUCTIONS AND WARNINGS PRIOR TO ASSEMBLING, INSTALLING, AND USING THIS PRODUCT.**

**Warning**



Always check for wires, fuel tanks and lines, brake lines and other important vehicle functionality items prior to drilling and installing all products.



**DO NOT EXCEED MANUFACTURERS WEIGHT CAPACITY FOR ROOF.**

**Tools Needed**

3/8" Socket and Wrench	1/2" Socket and Wrench
7/16" Socket and Wrench	

**Table of Contents**

Warning .....2

Tools Needed .....2

Parts List.....3

Parts List (Continued) .....4

Hardware .....5

Hardware (Continued).....6

Step 1 – Assemble Front Bow .....6

Step 2 – Install Spring on Front Bow ..... 10

Step 3 – Assemble Rear Bow ..... 11

Step 4 – Install Torque Tube..... 14

Step 5 – Install End Tube..... 15

Step 6 – Install Actuator..... 15

Step 7 – Install Gas Springs on Rear Bow ..... 16

Step 8 – Assemble Ladder Hooks ..... 17

Step 9 – Install Ladder Hooks..... 18

Step 10 – Install Ladder Stop..... 19

Step 11 – Test Ladder Rack .....20



**Before You Begin**

- Read all instructions.
- This kit is a driver side add on. A ladder rack must be assembled prior to installation of this kit.
- **DO NOT EXCEED MANUFACTURERS WEIGHT CAPACITY FOR ROOF.**

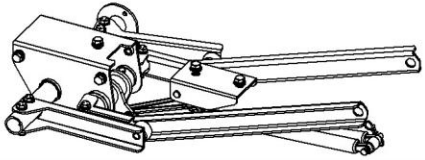
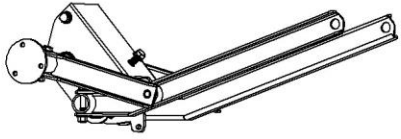
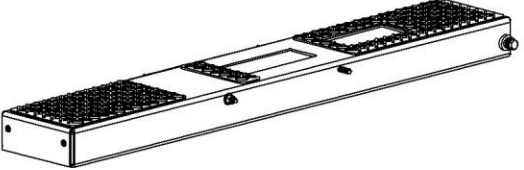
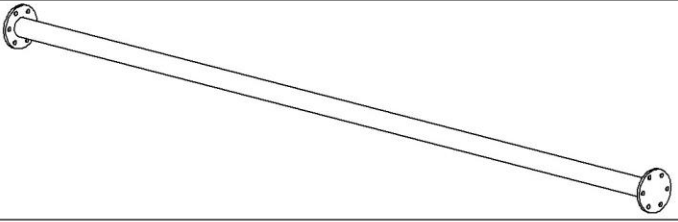
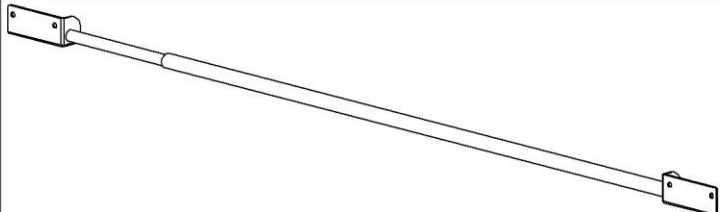
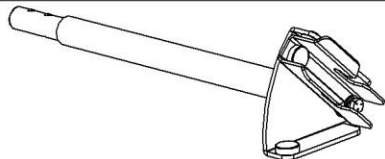
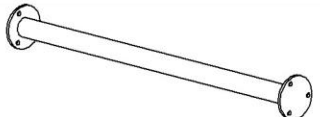

## Parts List

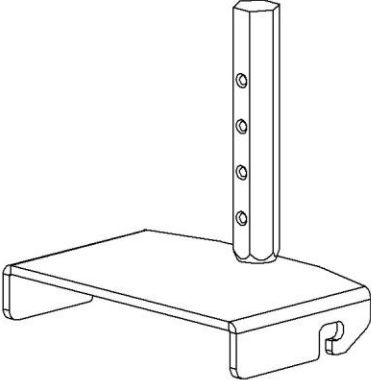
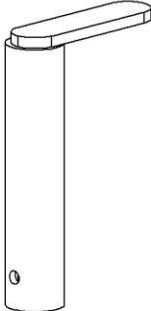
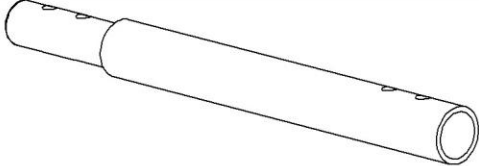
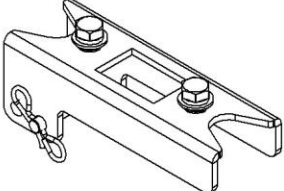
NO.	ITEM	PART NUMBER	DESCRIPTION	QTY.
1		4A99H-08	Rear Bow Mechanism Assembly	1
2		4A99H-09	Front Bow Mechanism Assembly	1
3		4A99H-30	Ladder Pan Assembly	2
7		40993-24	Torque Tube	1
5		4A93L-7	Support Tube Assy	1
6		40993-45	Torque Handle ASM	1
7		40993-25	Torsion Tube Extension	1

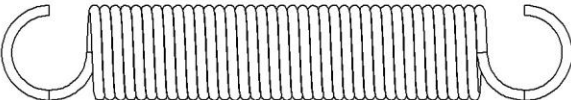

## Parts List (Continued)

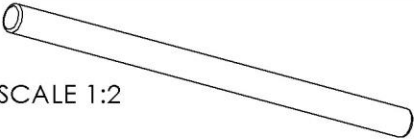
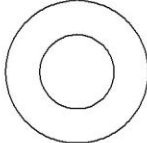
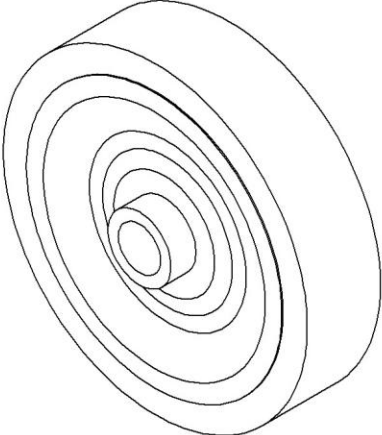
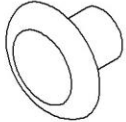
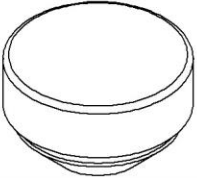
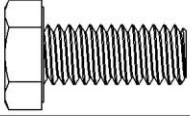
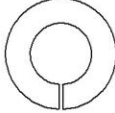
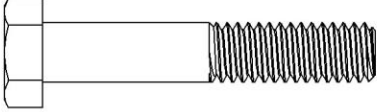
NO.	ITEM	PART NUMBER	DESCRIPTION	QTY.
8		4A900-36	Base Ladder Hook Weldment	2
9		4A900-35	Ladder Hook	2
10		40993-40-002	Actuator Extension	1
11		102271	Spring Mount Assembly	1
12		4A900-30-004	Ladder Stop	2
13		9640K144	Spring	1
14		18-4A91H	Hardware Kit	1

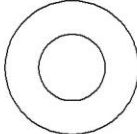
## Hardware

ITEM	HARDWARE TO SCALE	PART NUMBER	DESCRIPTION	QTY.
1	 <p>SCALE 1:2</p>	-	Axle	2
2		-	.39" ID X 3/4" OD FLAT NYLON WASHER	4
3		9960T26	2-1/4" x 9/16" Wheel	4
4		9960T26	Wheel Cap	4
5		-	1" OD RUBBER BUMPER, 1/2" HOLE, 5/16" THK	2
6		11241178	5/16-18 X 3/4" HEX HEAD BOLT	4
7		1133620	5/16" LOCKING WASHER	4
8		13010	5/16"-18 X 1-3/4" HEX HEAD BOLT	2
9		37521	5/16"-18 LOCK NUT	2
10		33006	5/16" FLAT WASHER	8

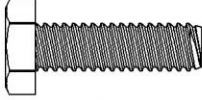
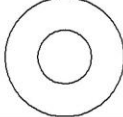
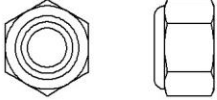
## Hardware (Continued)

ITEM	HARDWARE TO SCALE	PART NUMBER	DESCRIPTION	QTY.
11		95004	1/4"-20 X 7/8" HEX HEAD BOLT	11
12		33078	1/4" FLAT WASHER	20
13		37018	1/4"-20 NYLON INSERT LOCK NUT	9
14		33618	1/4" LOCK WASHER	2
15		Sealant - 60 ml	Self Leveling Adhesive Sealant	1

## Step 1 – Assemble Front Bow

- Attach the spring mount to the underside of the front bow using the pre-assembled hardware in the location and orientation shown. (Picture shown without mounting feet for clarity.)

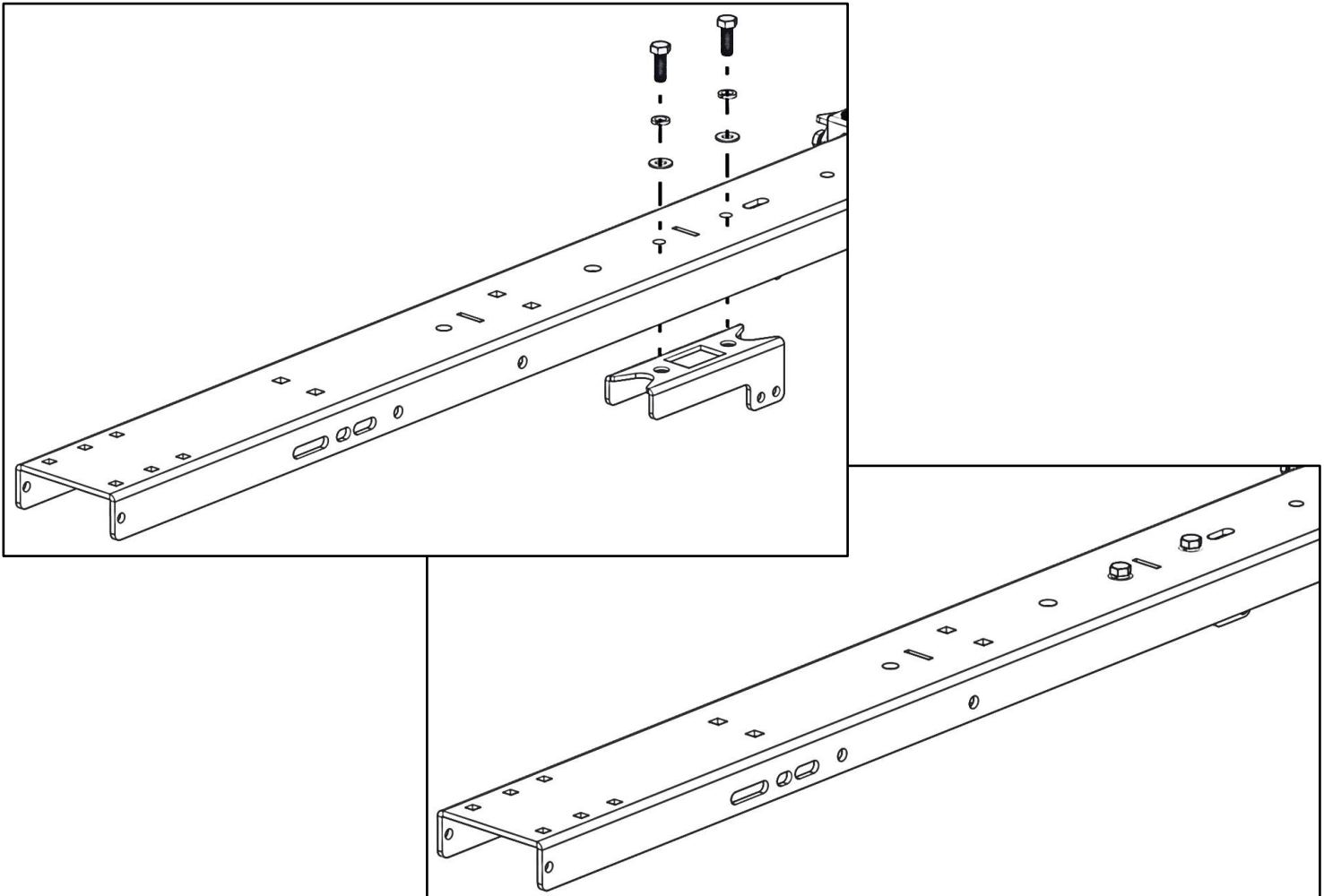

- Remove the 3/8" hardware from the front bow mechanism as shown.

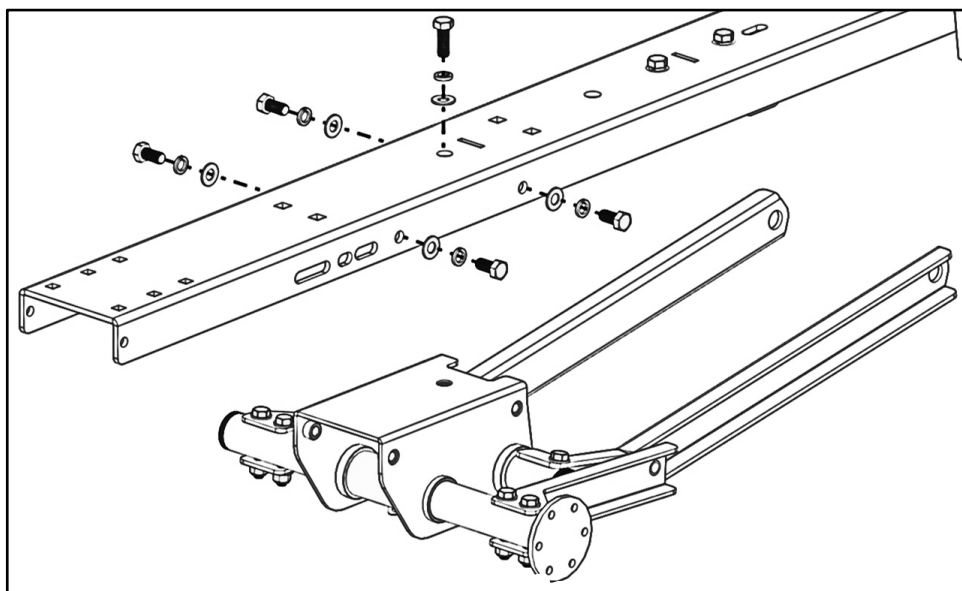

**Note: This is the mechanism with NO gas springs.**

- Attach the front bow mechanism to the underside of the front bow using the previously removed 3/8" hardware in the locations shown.
- **TIGHTEN.**
- Insert a rubber bumper in the round hole as shown. The large end of the bumper goes on top of the bow.

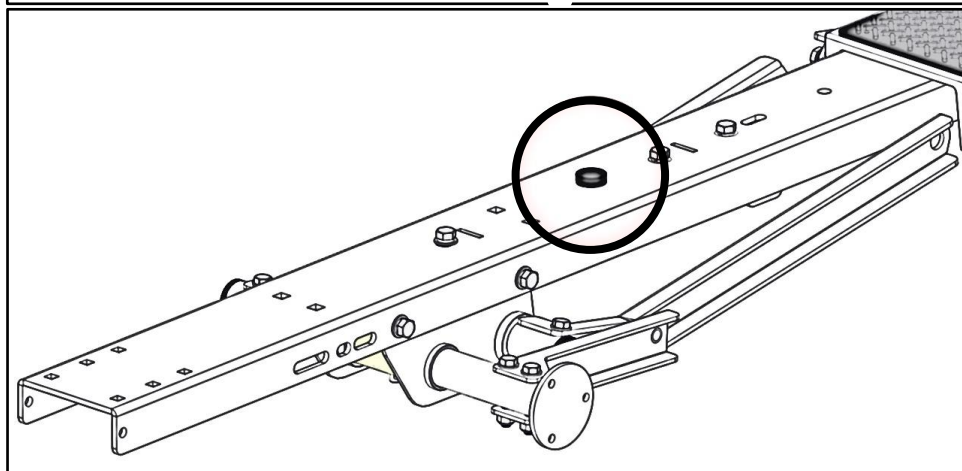

- Slide a wheel axle into the hole at the end of each bow.
- Place a nylon washer at each end of the axle on the outside of the bow.
- Install a wheel at each end of the axle.
- Cap each wheel with a wheel cap.

**WHEN INSTALLING THE PAN, BE SURE THE WHEEL CAPS STAY IN PLACE.**

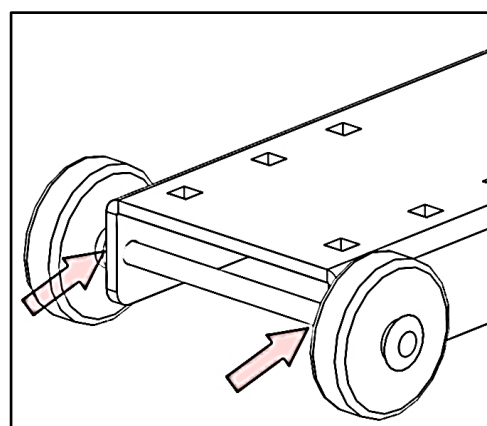
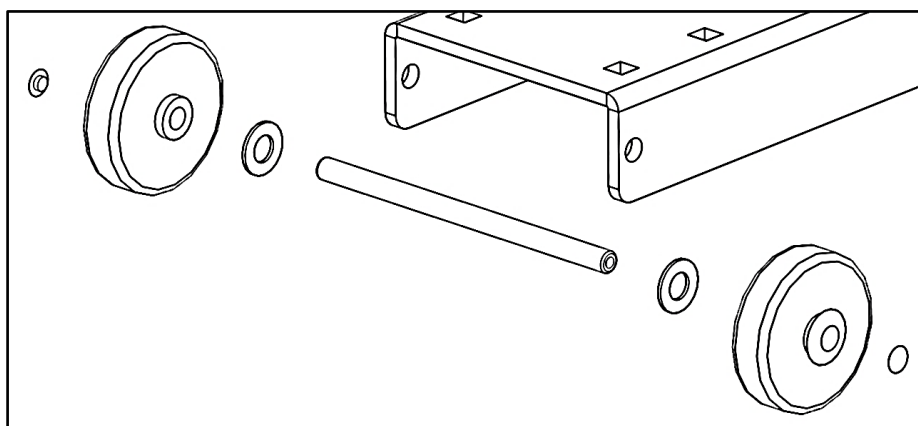



- Rotate the pan perpendicular to the top bow and at a slight angle as shown.
- Manuever the pan around the wheels.
- Ensure the wheels are contained inside the pan and lay the pan on top of the bow.

**BE SURE THE WHEEL CAPS DID NOT COME OFF.**

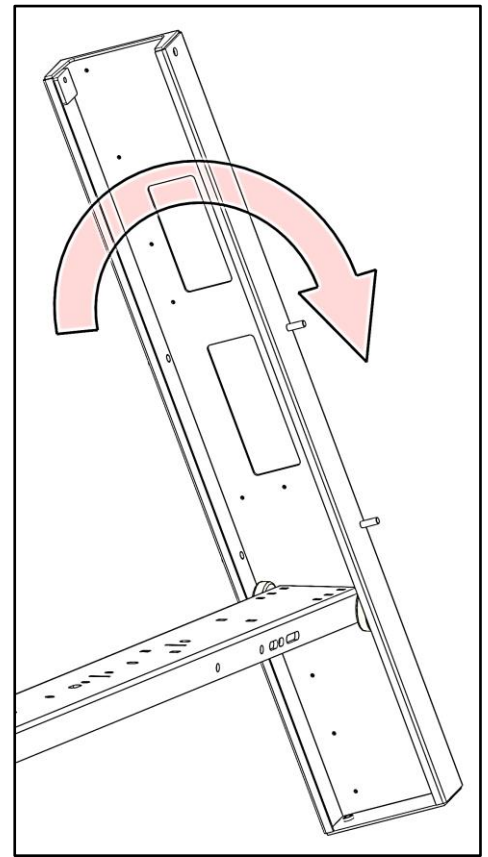
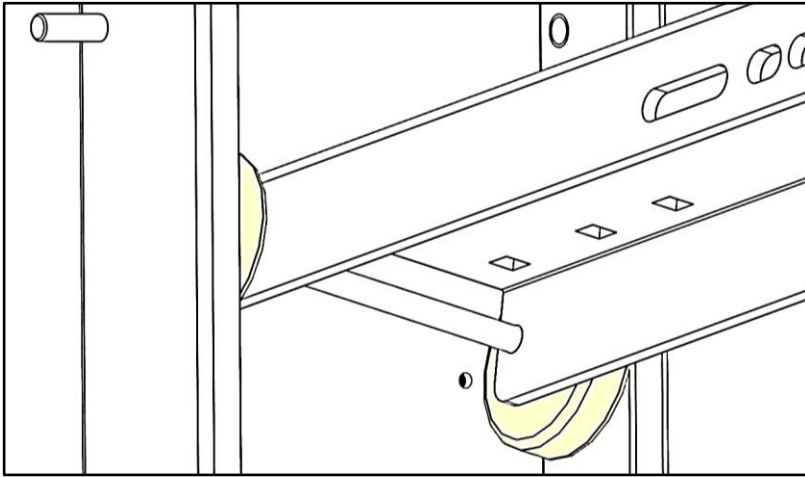

- Remove the hardware that is pre-assembled in the pan assembly (pictures shown without the bow for clarity).

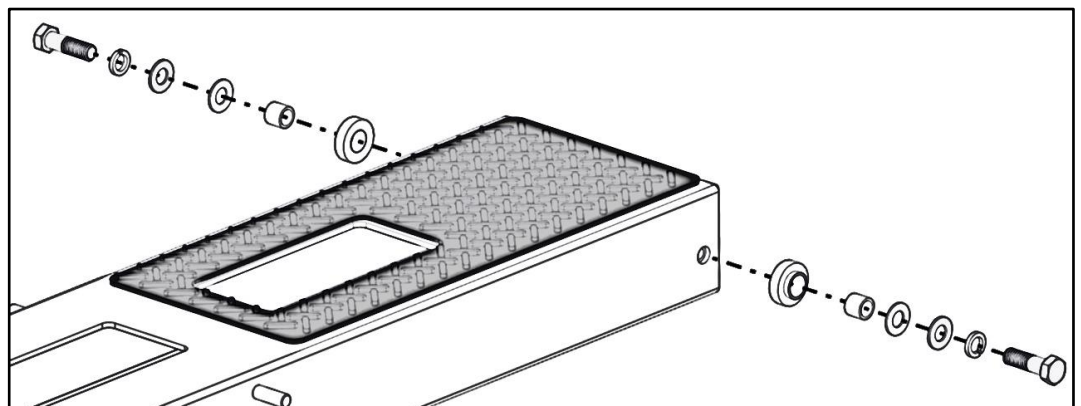
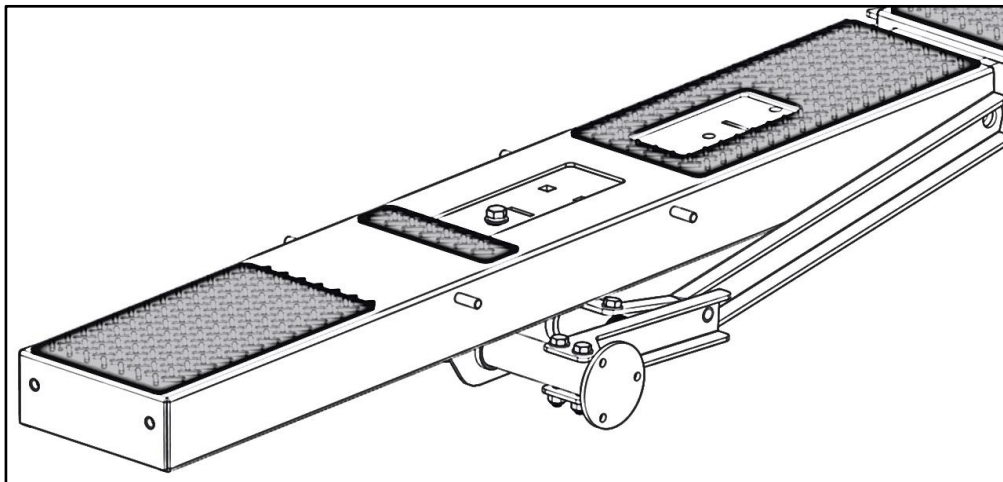



- Place the nylon spacer in between the pan and the arm on both sides.
- The nylon washer goes against the outside of each arm.
- Align the arms from the mechanism assembly with the holes in the pan.
- Reinstall the previously removed hardware in the orientation shown.
- **Do not over tighten. The pan and the arm are designed to rotate against each other.**

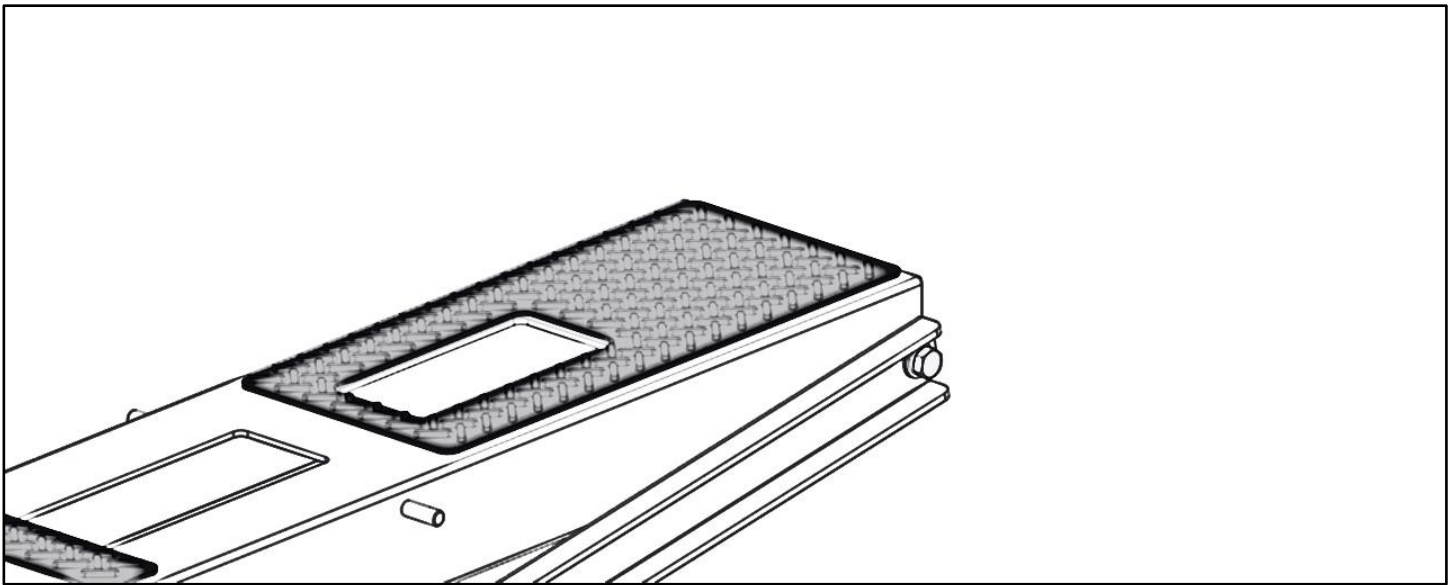
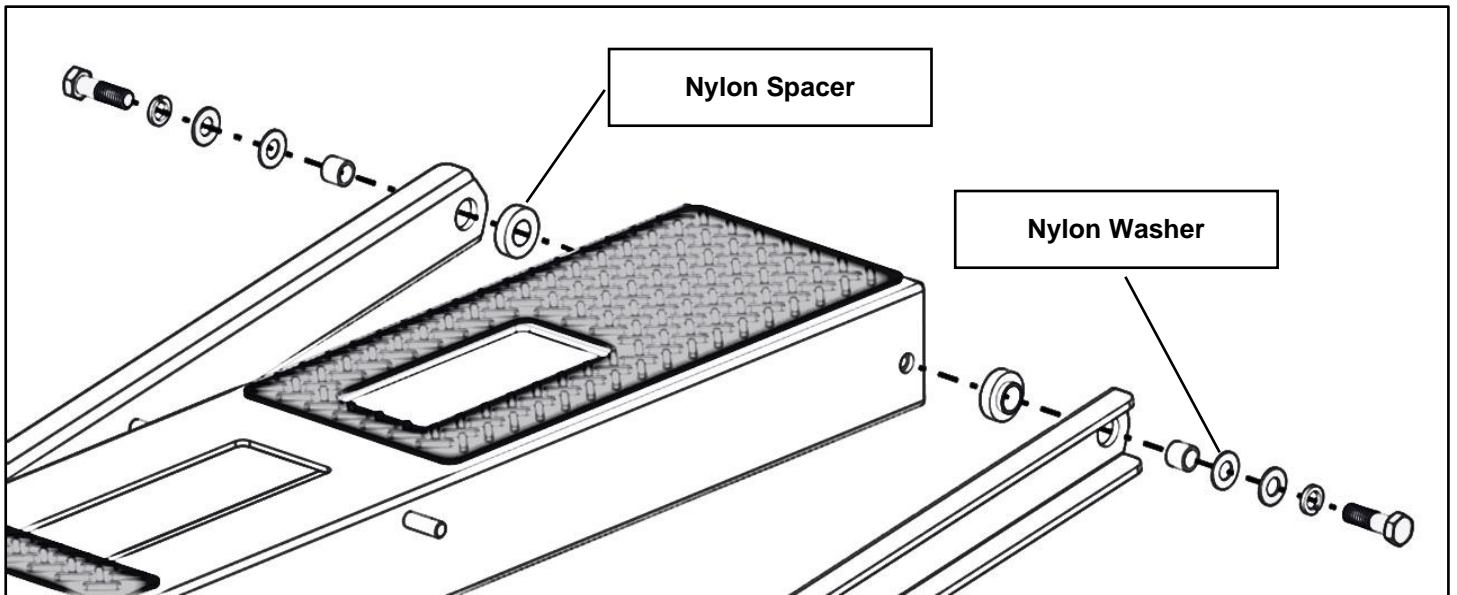

## **Step 2 – Install Spring on Front Bow**

- Hook the spring onto the pin in the spring mount bracket (shown without the bow for clarity).

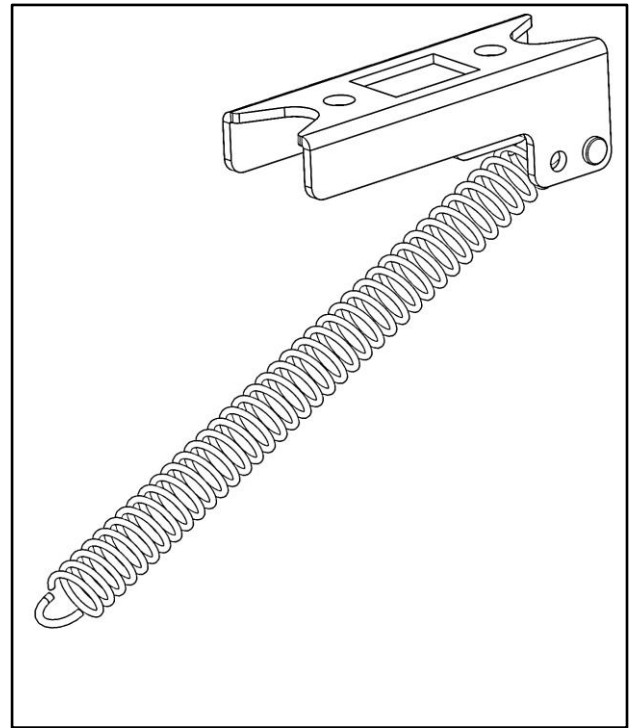
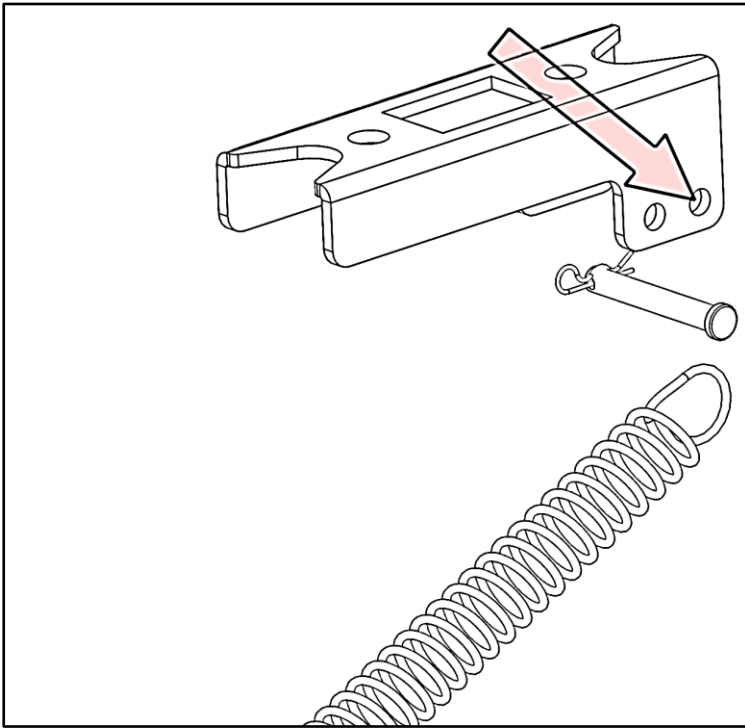

- Pivot the pan to allow the pivot mechanism to move closer to the spring mount bracket.
- Stretch the spring and hook onto the mount on the front pan mechanism.
- Return the pan to the down position.

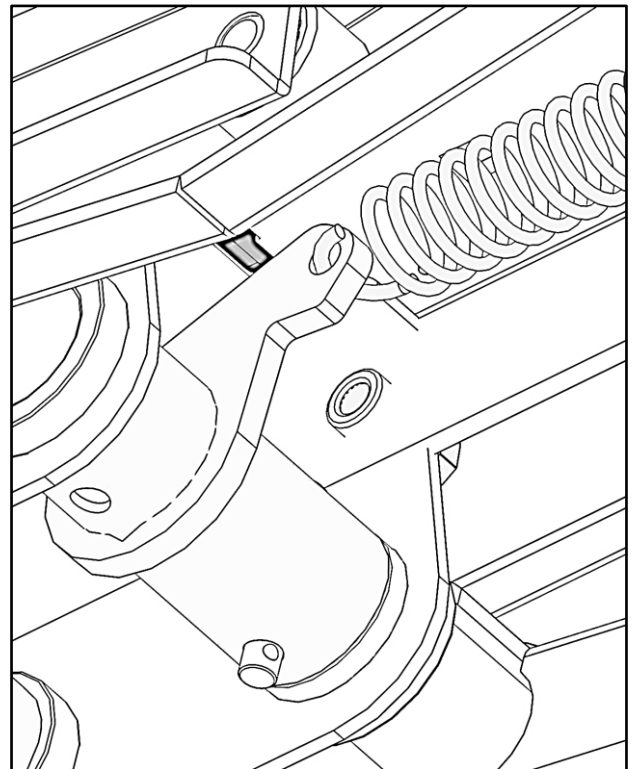

## **Step 3 – Assemble Rear Bow**

- Remove the 3/8" hardware in the rear bow mechanism as shown.

**Note:** This is the mechanism with the gas springs.

- Attach the rear bow mechanism to the underside of the rear bow using the previously removed 3/8" hardware in the locations shown.
- TIGHTEN.
- Insert a rubber bumper in the slot as shown. The large bumper goes on top of the bow.

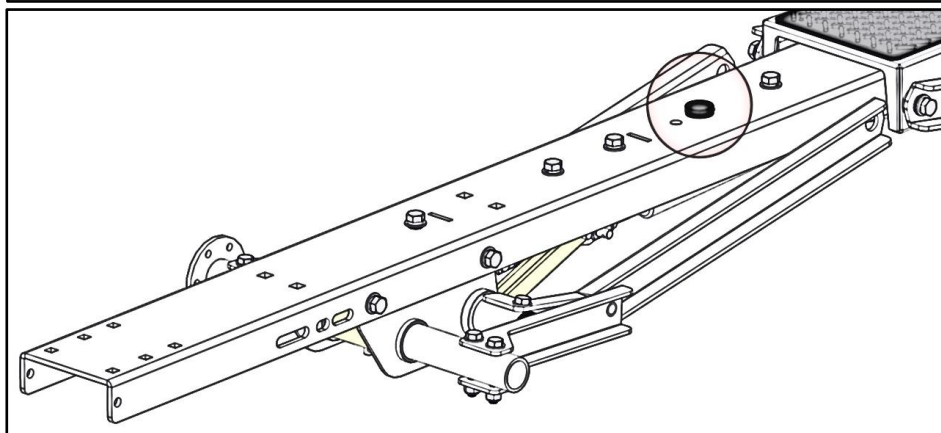
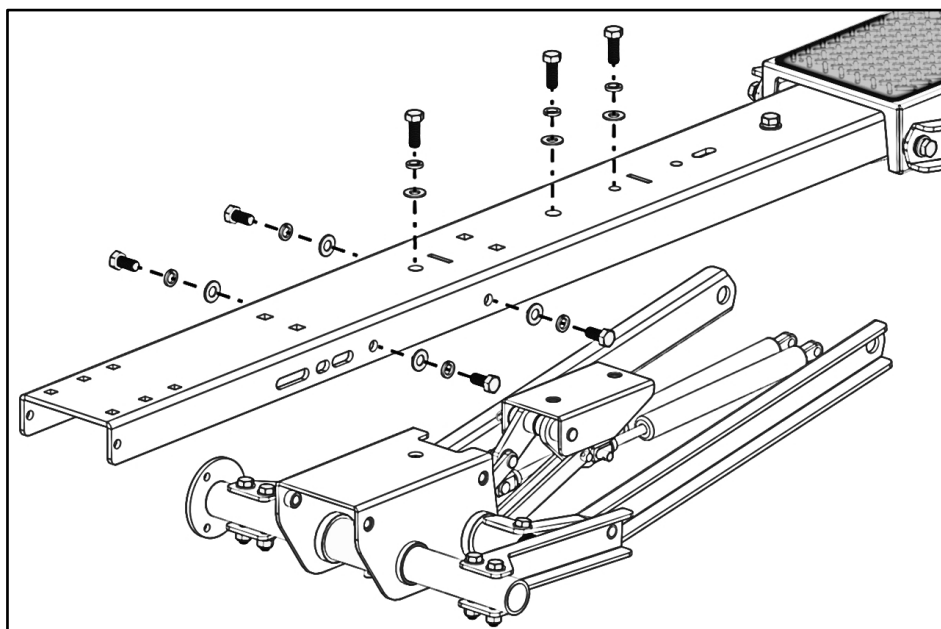

- Slide a wheel axle into the hole at the end of each bow.
- Place a nylon washer at each end of the axle on the outside of the bow.
- Install a wheel at each end of the axle.
- Cap each wheel with a wheel cap.

**WHEN INSTALLING THE PAN, BE SURE THE WHEEL CAPS STAY IN PLACE.**

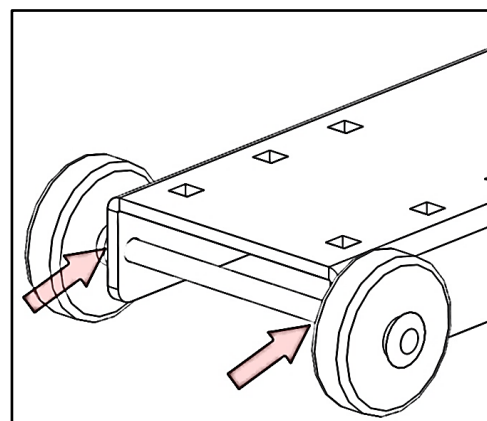
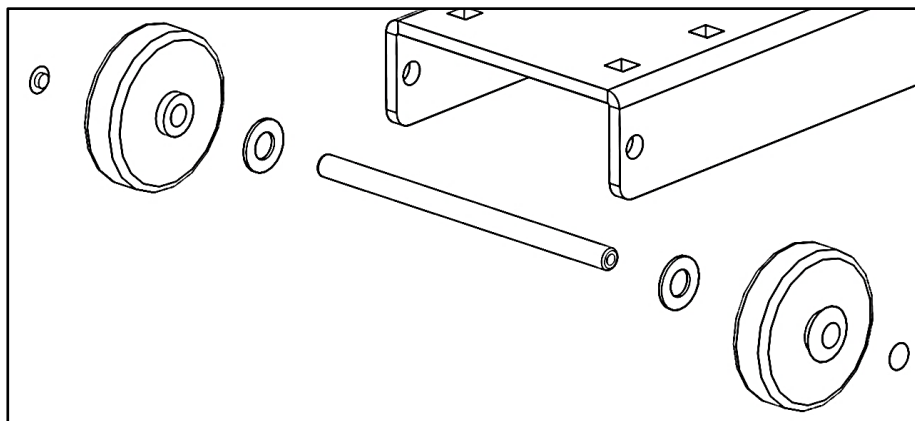

- Rotate the pan perpendicular to the top bow and at a slight angle as shown.
- The pan needs to be maneuvered around the wheels.
- Ensure the wheels are contained inside the pan and lay the pan on top of the bow.

**BE SURE THE WHEEL CAPS DID NOT COME OFF.**

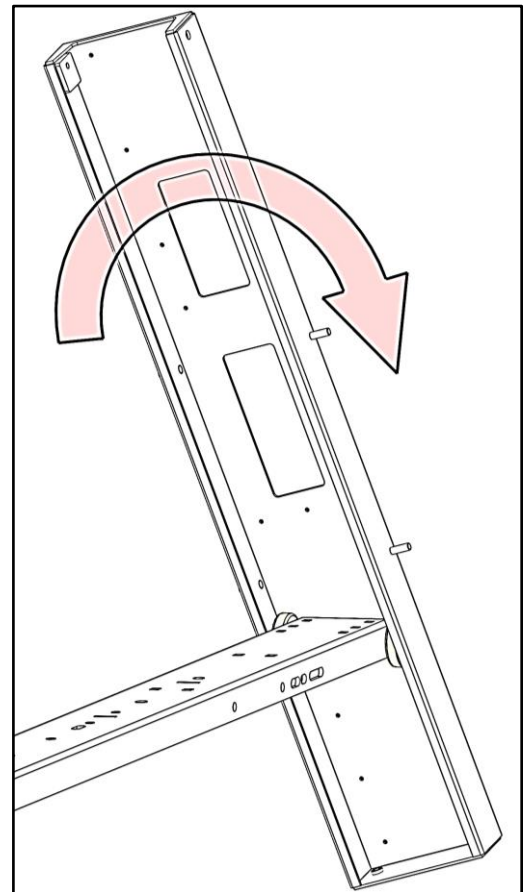
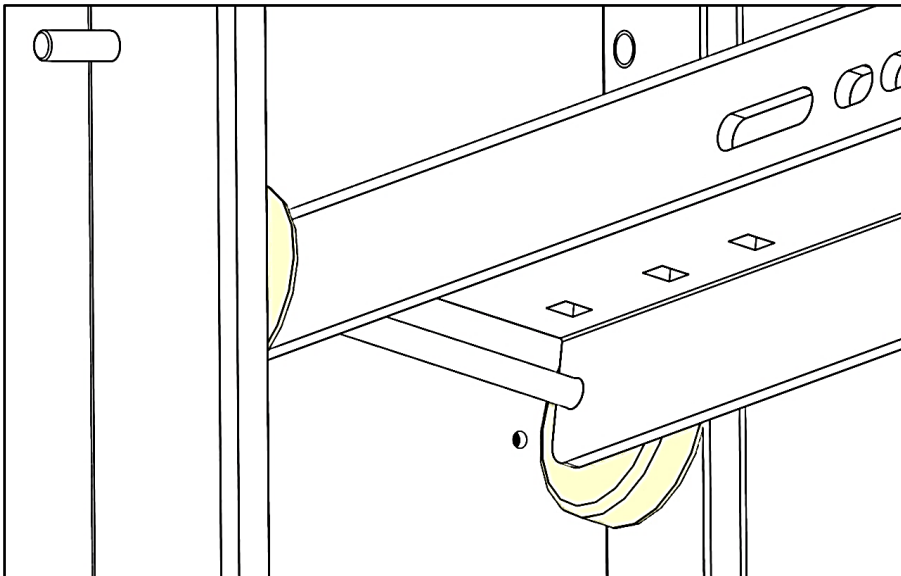

- Remove the hardware that is pre-assembled in the pan assembly (pictures shown without the bow for clarity).

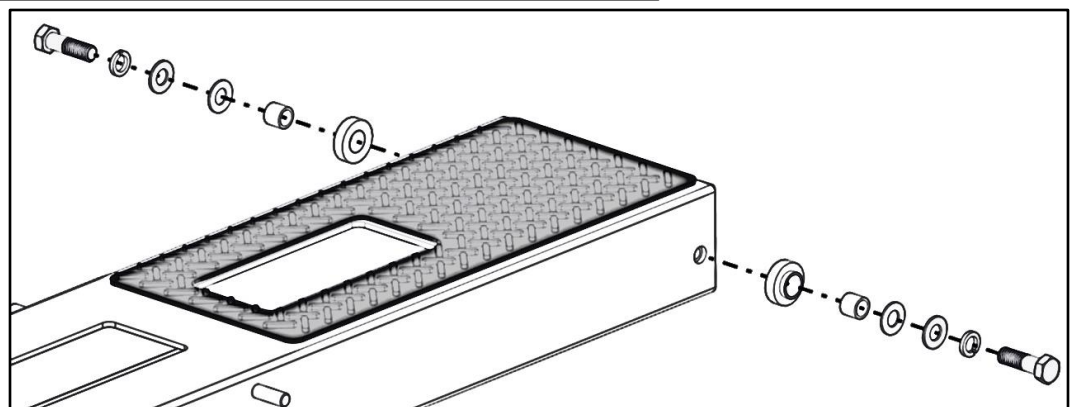
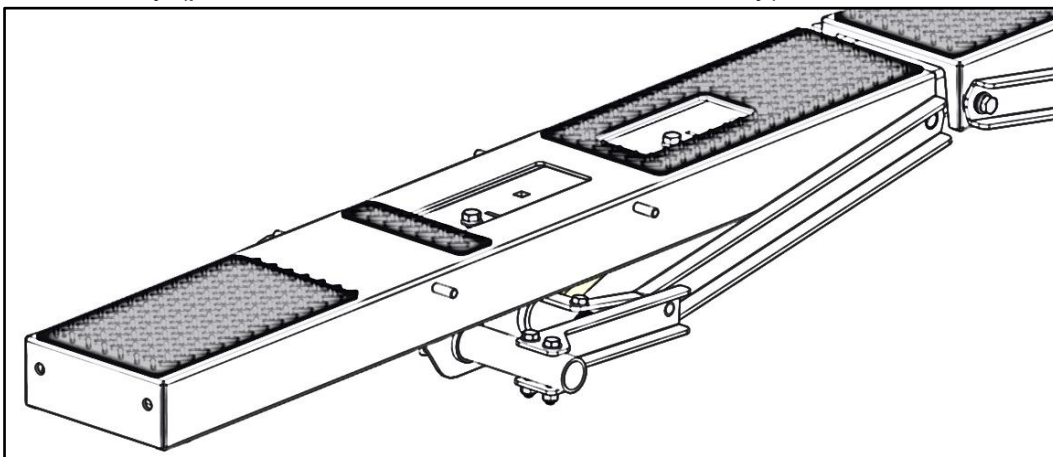



- Place the nylon spacer in between the pan and the arm on both sides.
- The nylon washer goes against the outside of each arm.
- Align the arms from the mechanism assembly with the holes in the pan.
- Reinstall the previously removed hardware in the orientation shown.
- **Do not over tighten. The pan and the arm are designed to rotate against each other.**

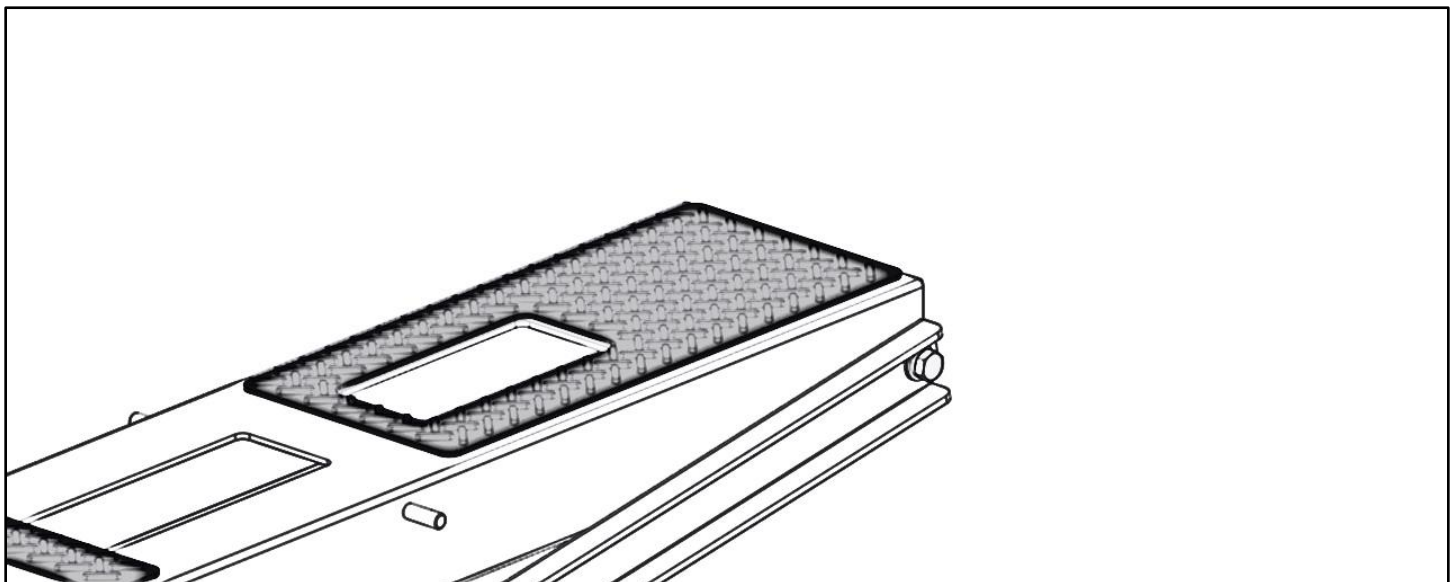
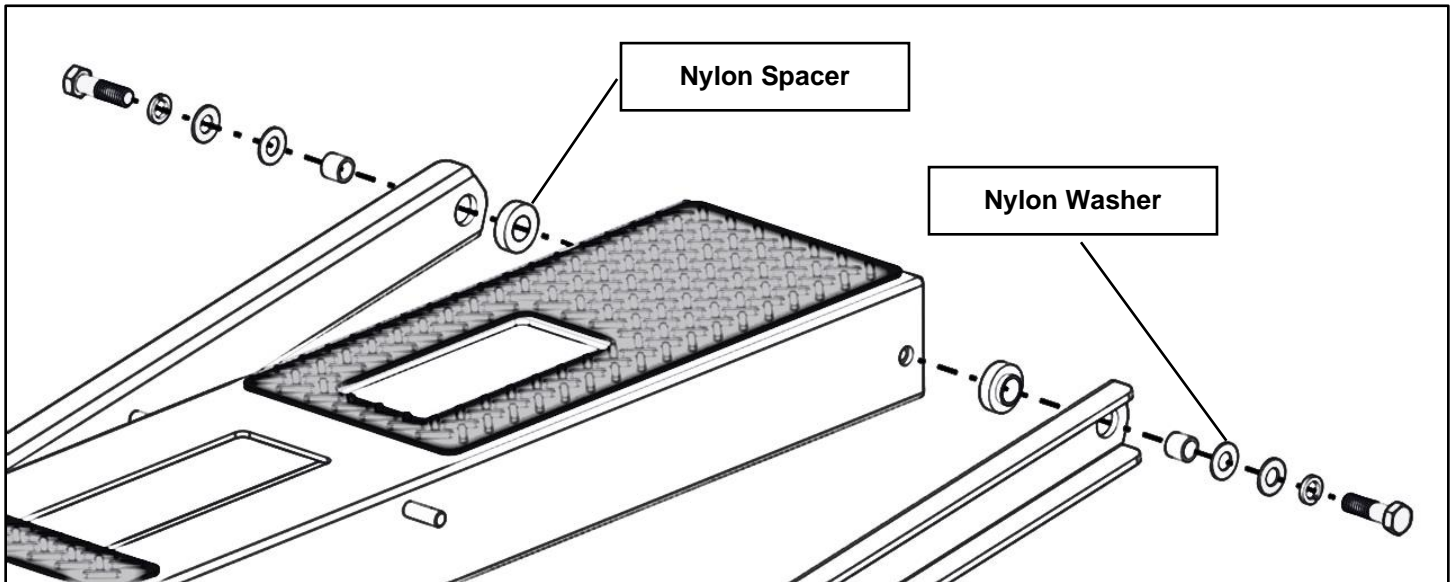

## Step 4 – Install Torque Tube

- Determine if the torque tube extension will be needed. Look at the passenger side for reference. The picture shown below shows the rack with the tube extension installed.

**Note: The extension is being used in the pictures.**

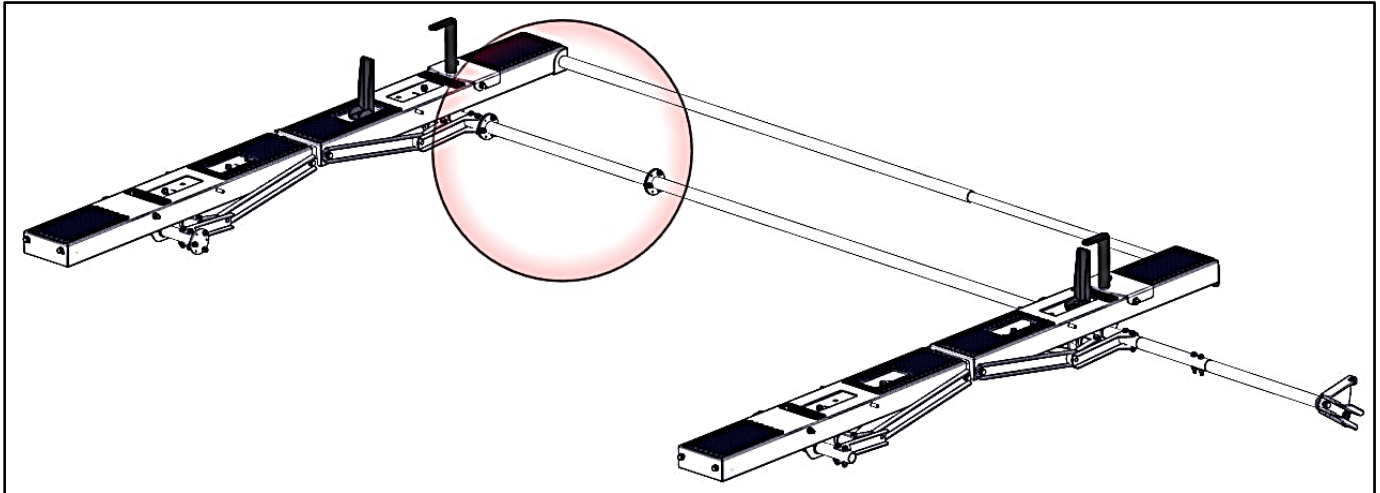

- Bolt the torque tube to the front and rear bow using 1/4" x 7/8" hex head bolts, 1/4" flat washers and 1/4" lock nuts.
- Repeat this process if the extension is being used.
- Snug tighten, but allow movement.

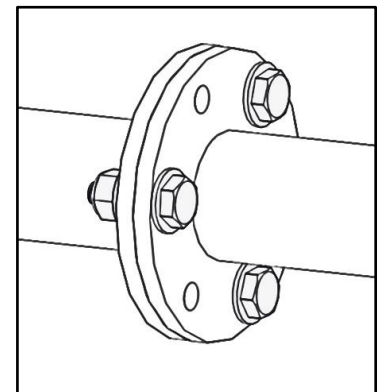
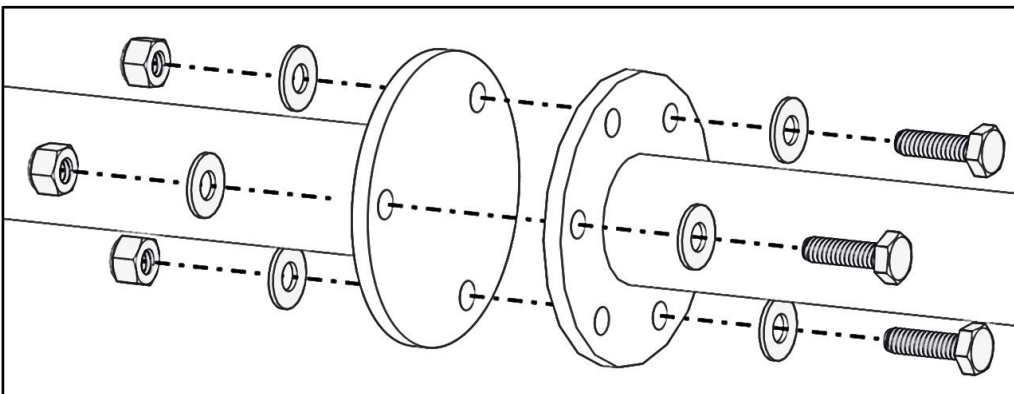
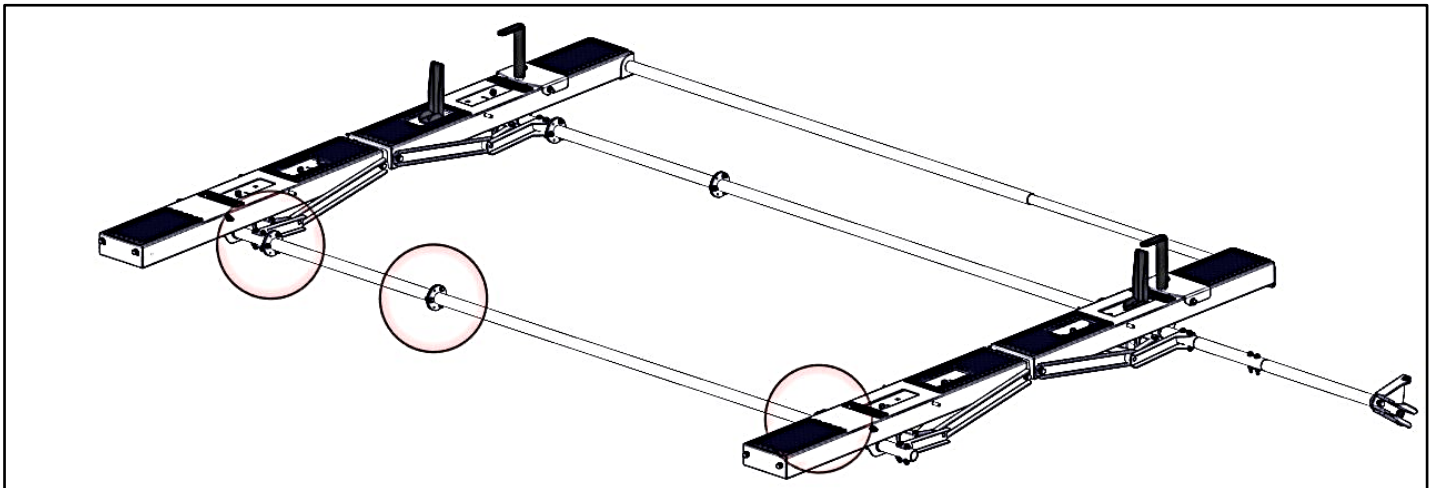



## Step 5 – Install End Tube

- Bolt the end tube assembly to the end of the pan on the front and rear bow using 5/16" x 3/4" hex head bolts, 5/16" lock washers and 5/16" flat washers.
- Snug tighten, but allow movement.

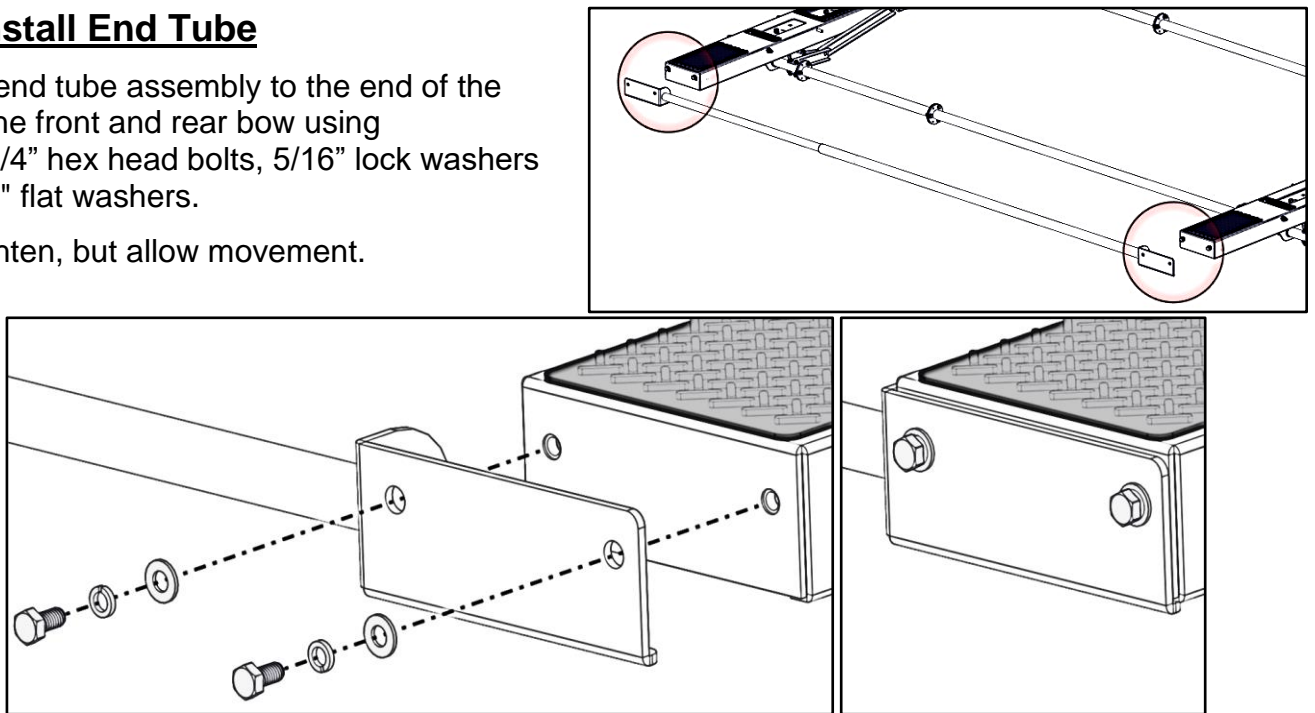

## Step 6 – Install Actuator

- Remove the hardware, as shown, from the tube on the rear bow.
- Insert actuator extension into the tube and attach using the previously removed hardware.
- Insert actuator assembly into the end of the actuator extension as shown below.
- Bolt into place using two 5/16" x 1-3/4" hex head bolts, four 5/16" flat washers and two 5/16" lock nuts.
- Tighten.

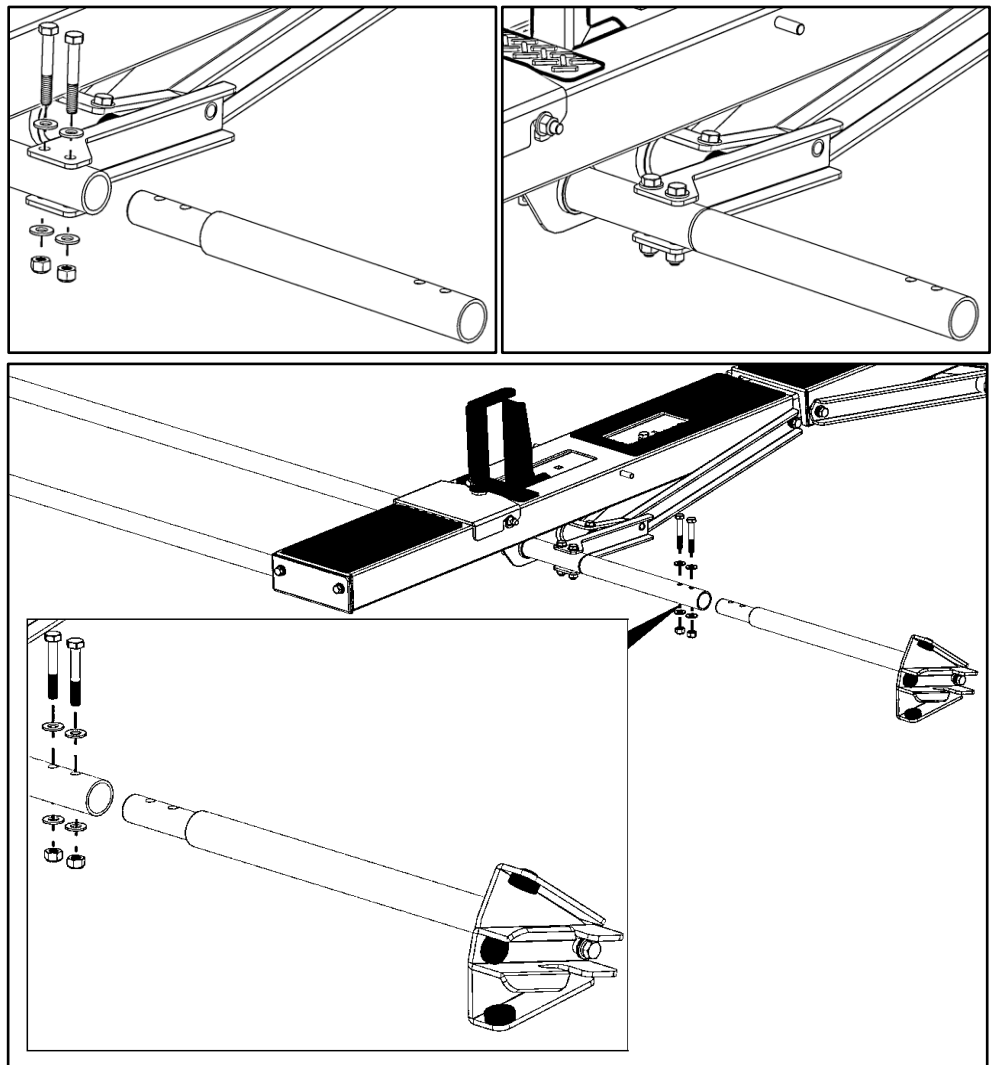

## **Step 7 – Install Gas Springs on Rear Bow**

- From the rear bow mechanism, remove the pin, spacer and the nylon washers that are pre-assembled between the gas springs.

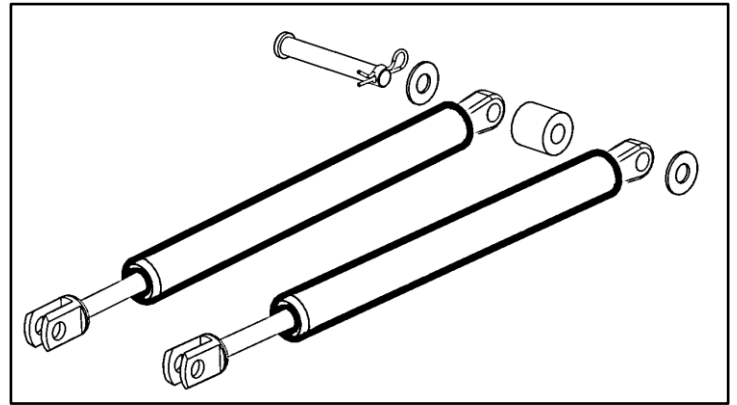

- Rotate the pan to a position so the mounts on the mechanism will allow installation of the gas springs.
- Use the pin, spacers and the nylon washers that were removed to attach the gas springs to the gas spring mount on the underside of the rear bow. The spacer goes in between the two gas springs. The nylon washers go in between the gas springs and the mount.

**Note:** In some situations, these gas springs can be installed easier by using the handle to help pivot the pan. The orientation of the gas springs may vary.

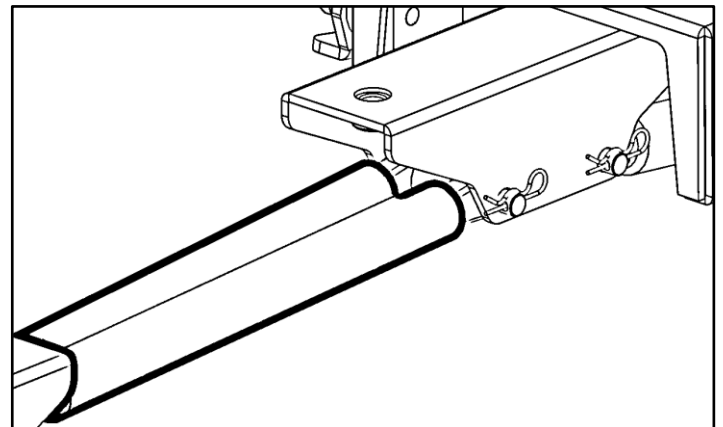
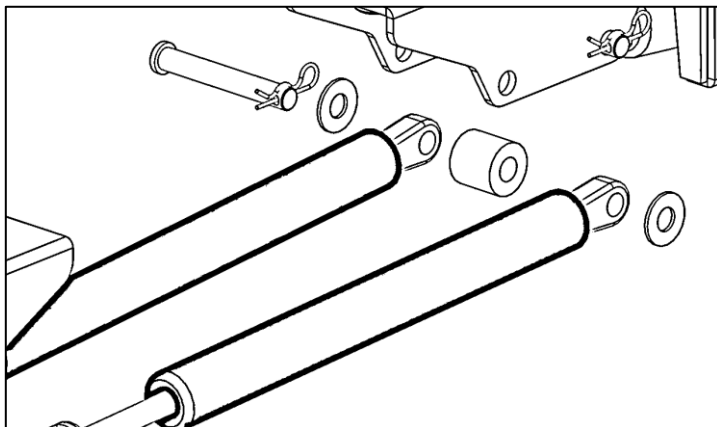
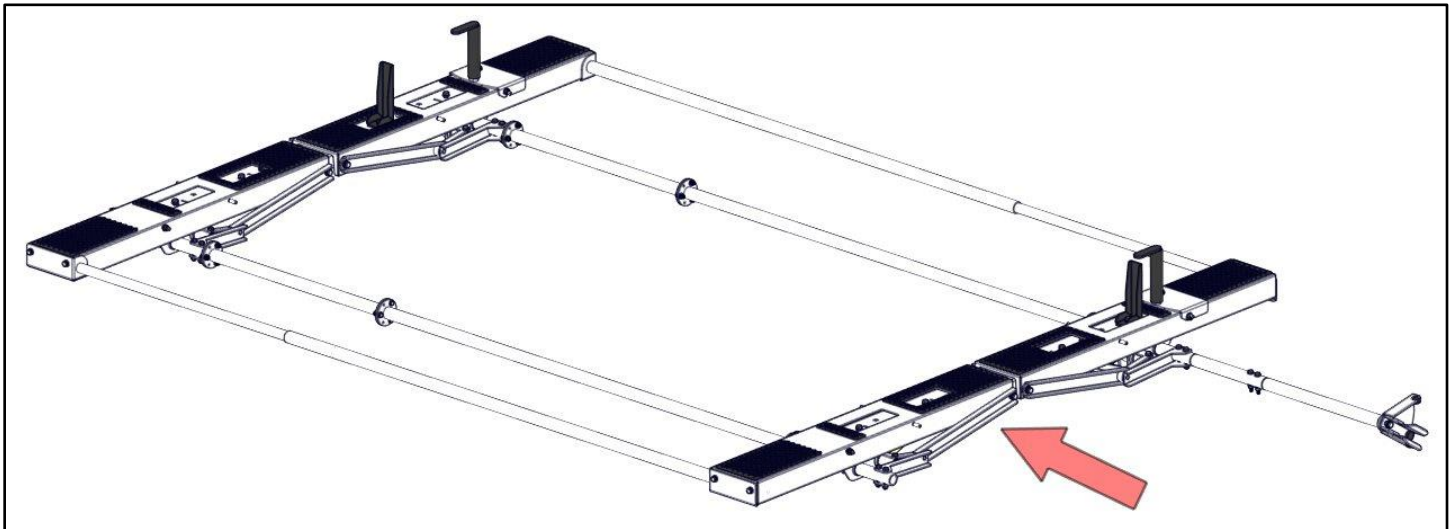

## Step 8 – Assemble Ladder Hooks

**Note:** Before use the ladder hook must be adjusted to an appropriate height for the ladder that will be used. The height of the hook needs to be at least 1/4" greater than the ladder. The ladder should fit loosely on the hook, not snug.

- Measure the thickness of the ladder that will be used and determine the appropriate mounting hole on the ladder hook weldment that will allow for a loose fit.
- **Be sure the height of the hook is AT LEAST 1/4" GREATER THAN the thickness of your ladder.**
- If you are unsure of the thickness of the ladder that will be used, set the height of the hook to the highest setting (9 inches) and adjust it later.

**NOTE:** Roof height clearance is affected by the hook mounting location used. Please verify and be aware of the total height of the vehicle with rack installed.

- Using a 1/4" x 1" hex head, a 1/4" lock washer and a 1/4" flat washer, bolt ladder hook assembly to ladder hook weldment using the previously determined mounting location.
- Tighten.

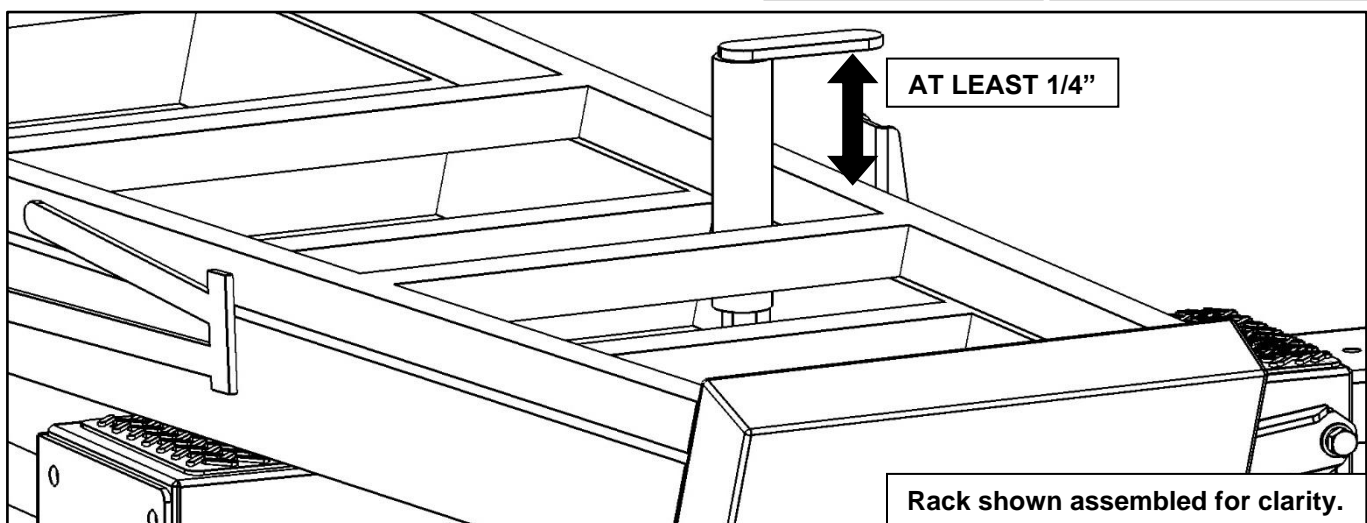
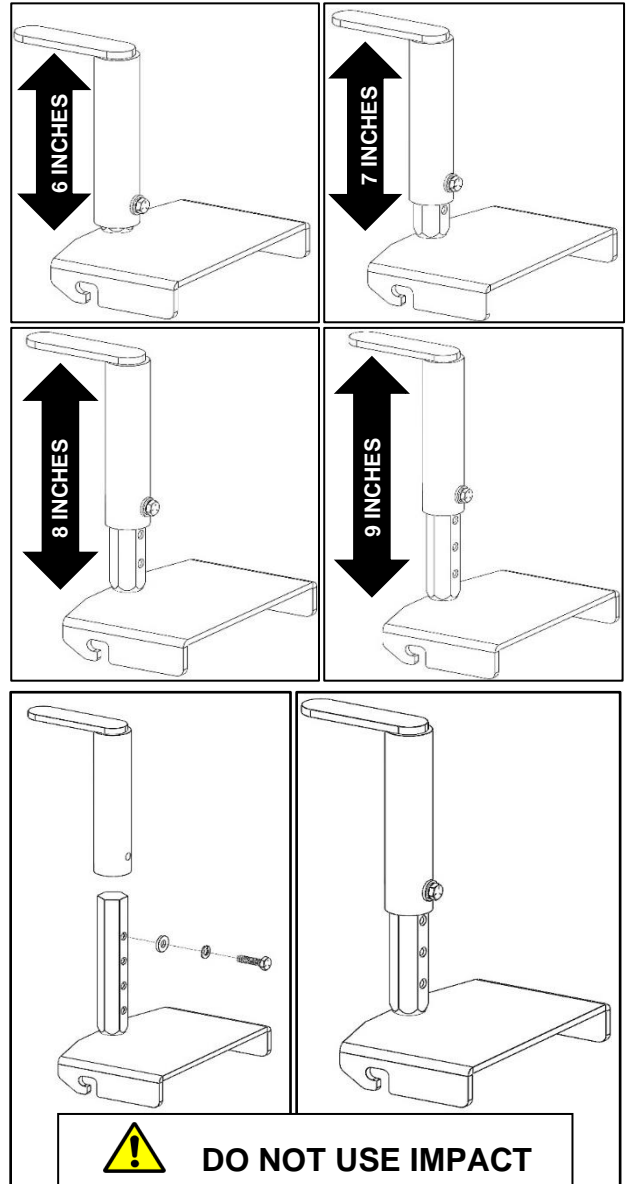

## Step 9 – Install Ladder Hooks

- Place one ladder hook assembly onto the front bow and one ladder hook on the rear bow.
- There are two threaded studs to choose from on each bow. The ladder being used on the ladder rack will determine which location is used.

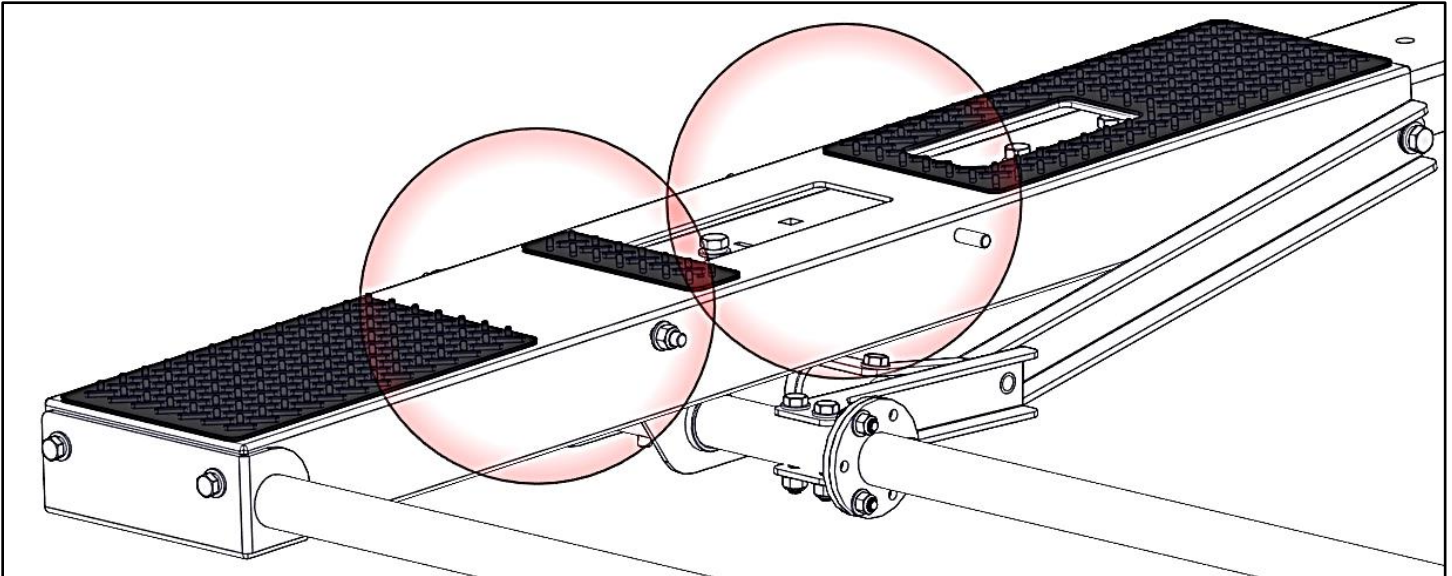

- Bolt into place using the pre-assembled hardware on both front and rear pan.

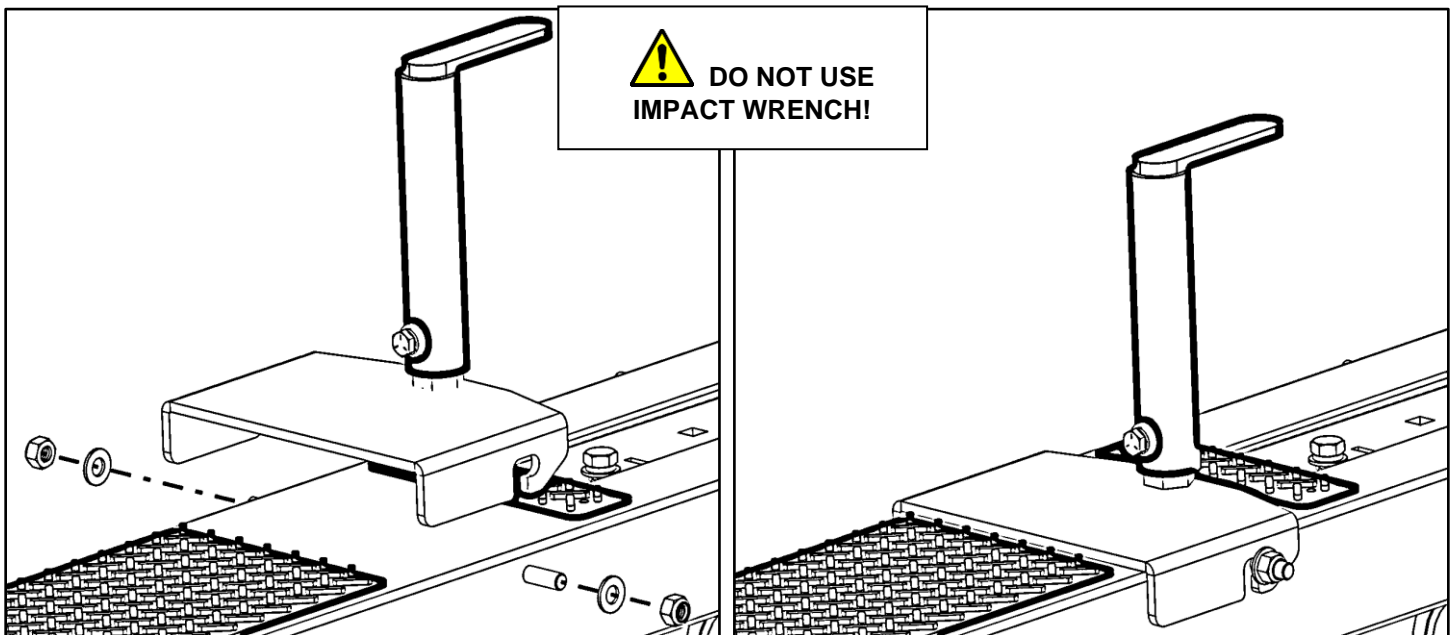



## Step 10 – Install Ladder Stop

- Find the slot and the installed hardware near the previously installed ladder hook assembly.
- Remove the hardware in the bow and place the ladder stop in that location.
- Bolt into place using the removed hardware. **Be sure the tab on the ladder stop aligns with the slot in the bow.**
- Repeat on each bow.
- Tighten.

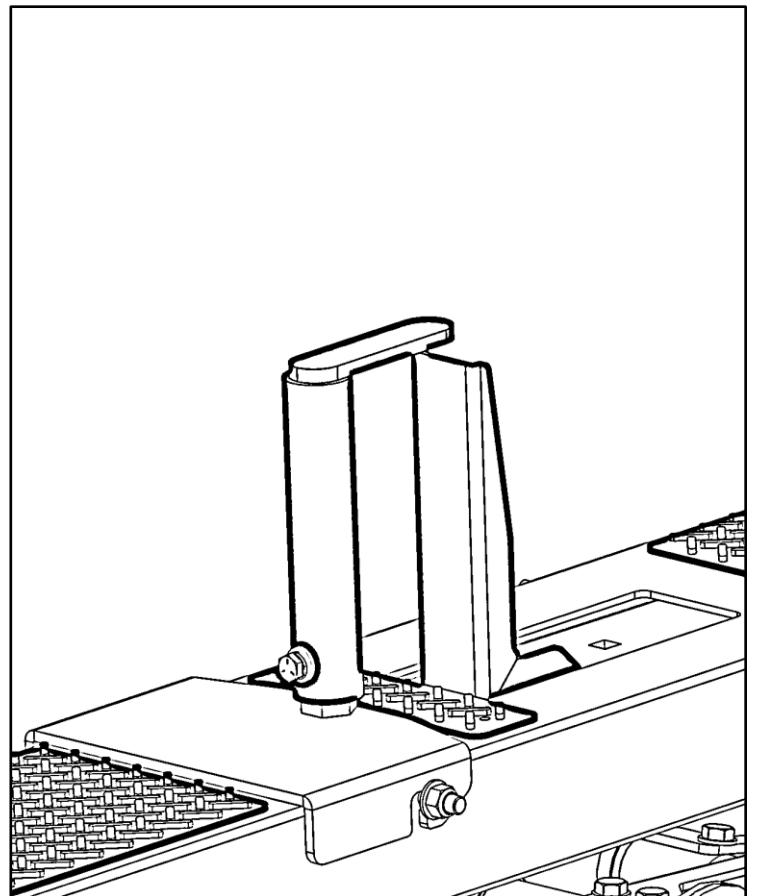
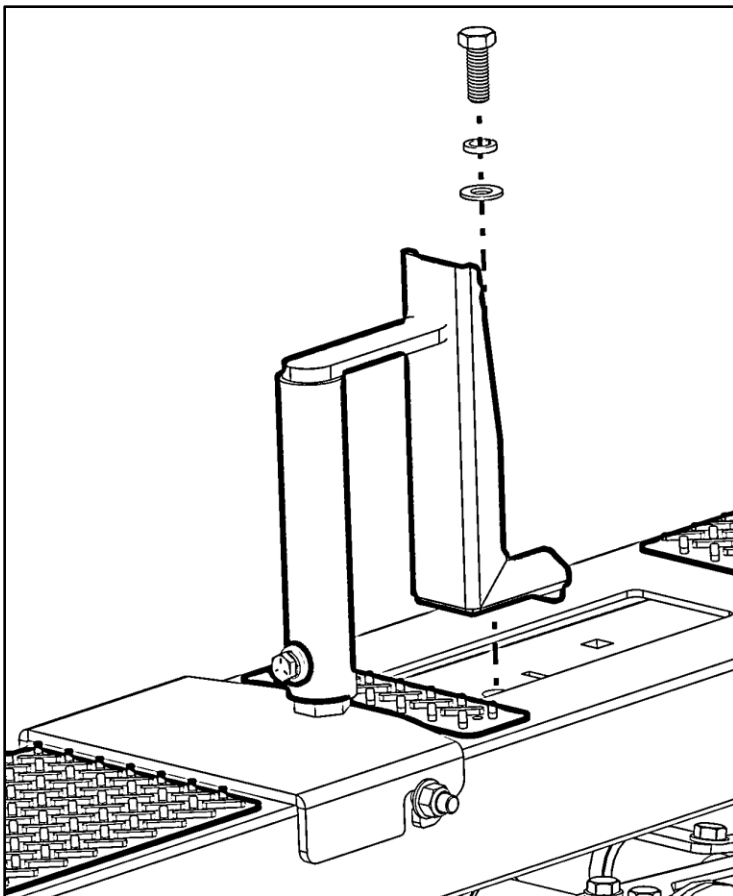
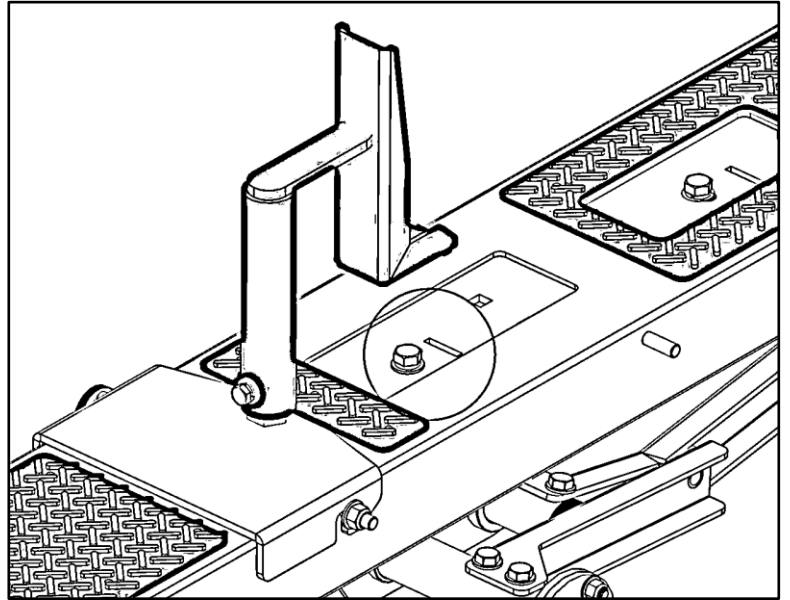

## **Step 11 – Test Ladder Rack**

- Go back and ensure all hardware is tight. Start by tightening the torque tube first.
- Prior to installing a ladder, place the long handle into the handle bar assembly and test that the ladder rack mechanism works correctly.

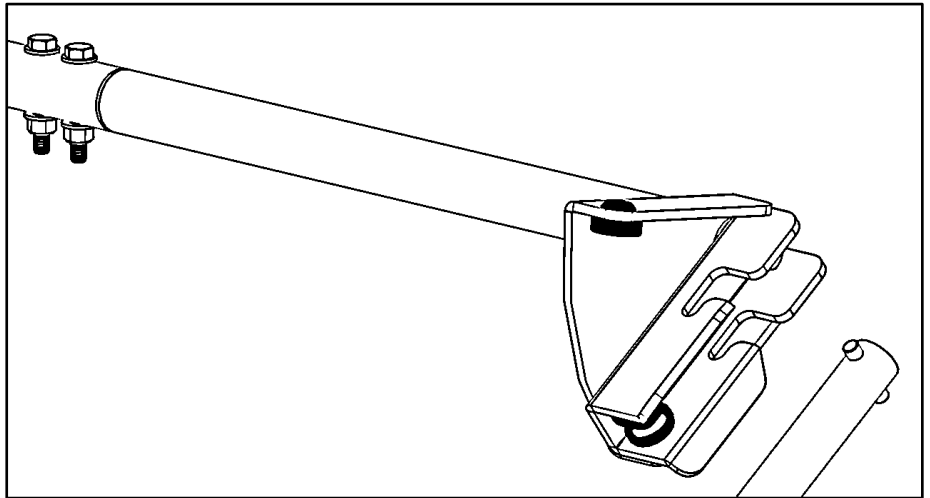

**ENSURE ALL HARDWARE IS TIGHT.**

**YOUR INSTALLATION IS NOW COMPLETE.**

