

Holman

Instruction Guide 4A97L

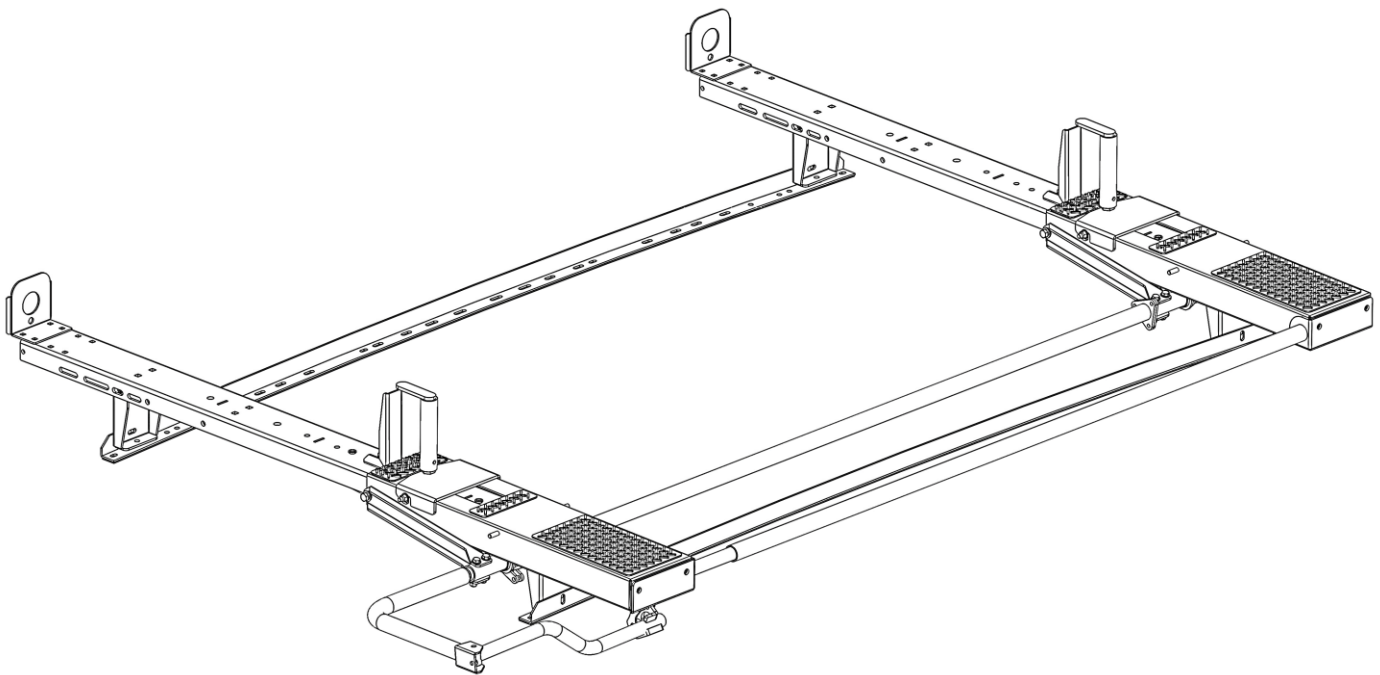

Holman
Rancho Cordova, CA 95742
800-343-7486

InstallationSupport@Holman.com

PLEASE READ ALL INSTRUCTIONS AND WARNINGS PRIOR TO ASSEMBLING, INSTALLING, AND USING THIS PRODUCT.

Warning



Always check for wires, fuel tanks and lines, brake lines and other important vehicle functionality items prior to drilling and installing all products.

DO NOT EXCEED MANUFACTURERS WEIGHT CAPACITY FOR ROOF.

Tools Needed

5/16" Wrench and Socket	3.8" Wrench and Socket
1/2" Wrench and Socket	1/2" Wrench and Socket
Tape Measure	

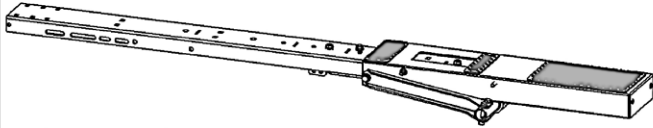
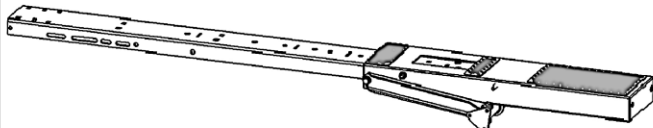

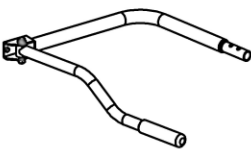



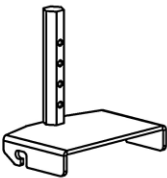

Table of Contents

Parts List.....	2
Hardware	4
ProMaster City Rail Installation.....	6
NV200/City Express Rail Installation	7
Transit Connect Rail Installation	8
Metris Rail Installation.....	9
Assembly Instructions.....	10
Step 1 – Install End Stops.....	10
Step 2 – Determine Front and Rear Bows	10
Step 3 – Mount Feet to Rails.....	11
Step 4 – Place Bows on Feet.....	12
Step 5 – Install Torque Tube.....	13
Step 6 – Install Ladder Pan Stiffener	14
Step 7 – Install Ladder Hooks	15
Step 8 – Install Latch	17
Step 9 – Install Handle.....	17
Step 10 – Assemble Ladder Hooks.....	18



Before You Begin

- Read all instructions prior to installing any Holman product.
 - **Be sure to apply sealant in the following location.**
 - Between roof and mounting rails, and around the holes in the roof.
 - Around all threads entering cargo area.
 - Between the rubber spacer and roof of vehicle to prevent water from leaking into cargo area.
 - Around all swage joints to avoid water from leaking inside of ladder rack.
-





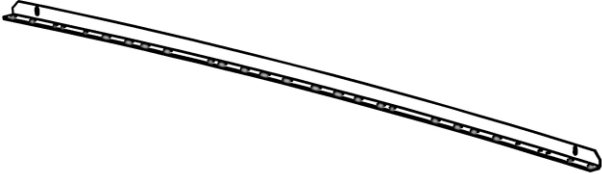

Parts List

ITEM NO.		PART NUMBER	DESCRIPTION	QTY.
1		4A97L-1	FRONT BOW	1
2		4A97L-2	REAR BOW	1
3		4A93L-7	LADDER PAN STIFFENER	1
4		4A97L-40	HANDLE ASSEMBLY	1
5		4A93L-50	TORQUE TUBE	1
6		4A92L-44	LATCH	1
7		4A900-35	LADDER HOOK	2
8		4A900-36	LADDER HOOK BASE	2
9		4A900-30-004	LADDER STOP	2

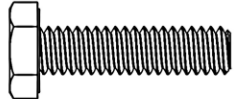

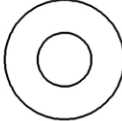

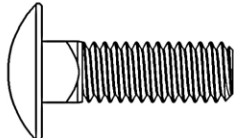
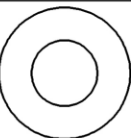
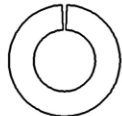
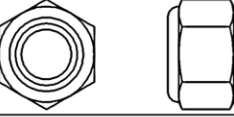
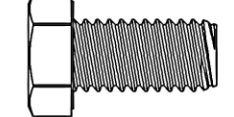
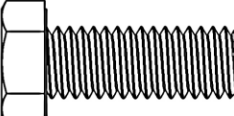
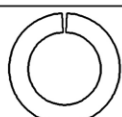
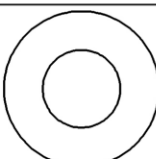
Parts (Continued)

ITEM NO.		PART NUMBER	DESCRIPTION	QTY.
10		4A900-10-008	END STOP	2
11		4A933-10	FOOT	4
12		4A800-02	MOUNT RAIL	2
		18-4A97L	HARDWARE, DROP DOWN, MINI	1

Hardware

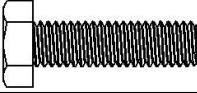
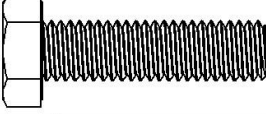
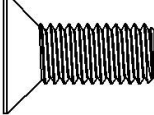
NO.		PART NUMBER	DESCRIPTION	QTY.
1		92865A542	BOLT, HEX, 1/4-20 x 1"	8
2		92148A180	WASHER, LOCK, 1/4	8
3		90126A029	WASHER, FLAT, 1/4"	20
4		95615A120	NUT, NYLOK, 1/4-20	6
5		90185A583	BOLT, CARRIAGE, 5/16-18 X 1	10
6		90126A030	WASHER, FLAT, 5/16, SAE	14
7		312 LW	5/16" LOCKING WASHER	4
8		95615A160	NUT, NYLOC, 5/16-18	10
9		92865A622	BOLT, HEX, 3/8-16 X .75"	4
10		92865A624	BOLT, HEX, 3/8-16 X 1"	9
11		91102A760	WASHER, LOCK, 3/8	12
12		90126A031	WASHER, FLAT, 3/8, SAE	14
13		97135A230	NUT, HEX, NYLOK, 3/8-16	1

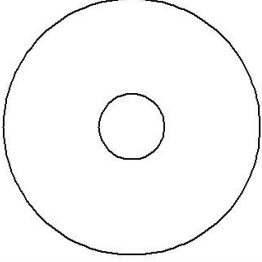
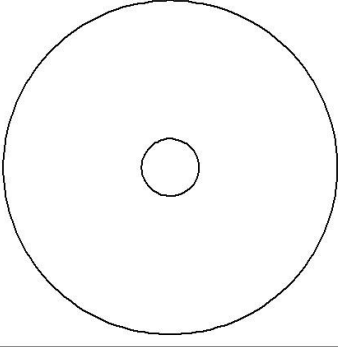
Hardware (Continued)

NO.		PART NUMBER	DESCRIPTION	QTY.
14		91287A137	M6 X 1.0 X 22MM HEX HEAD BOLT	6
15		91287A154	BOLT, HEX, M8 X 1.25 X 30MM	4
16		GRADE 8.8	M8-1.25 X 25 FLAT HEAD SOCKET CAP SCREW	4
17		93625A300	NUT, NYLOK, M8 X 1.25	4
18		312 FNDR	5/16" FENDER WASHER	4
19			WASHER, 5/16 X 1.75" OD X .125" THK, RUBBER	6
		Sealant - 60 ml	Self Leveling Adhesive Sealant	1

DO NOT EXCEED MANUFACTURERS WEIGHT CAPACITY FOR ROOF **ProMaster City Rail Installation**

- Locate the 6 mounting locations shown on roof of van.
- Remove plugs from roof.
- Place the rail on the roof so the holes align with the threaded holes in roof. In most installs, the rail upright flange is to the outside of the van.

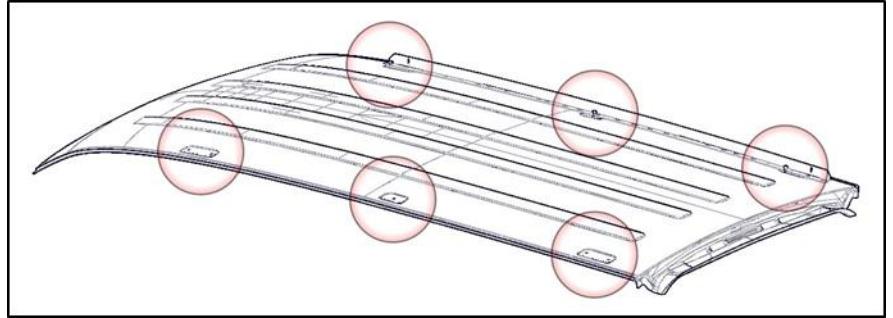

- Insert rubber washer between the mounting rail and the roof to ensure sealing.
- Place sealant on and around threaded holes and bolt threads to seal roof. (Passenger side shown)
- Install mounting rail as shown using M6 x 22mm bolts, 1/4" lock washers, and 1/4" flat washers. **Be sure to apply sealant around bolts as you fasten them.**

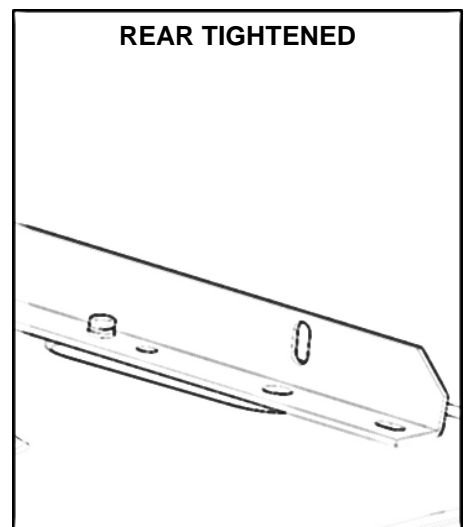
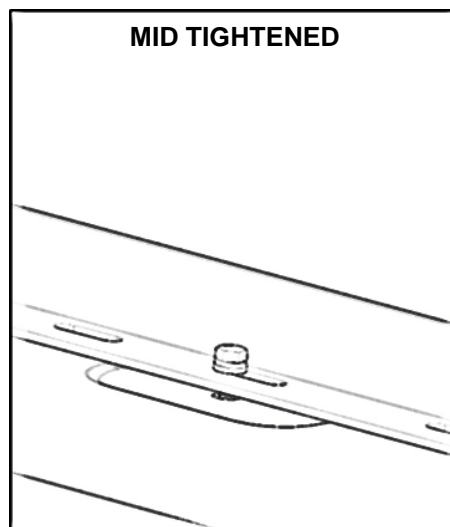
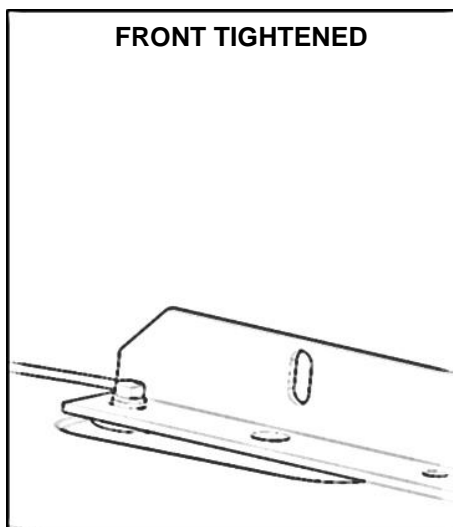
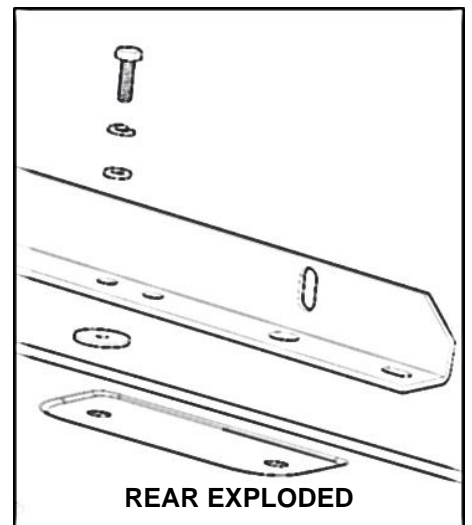
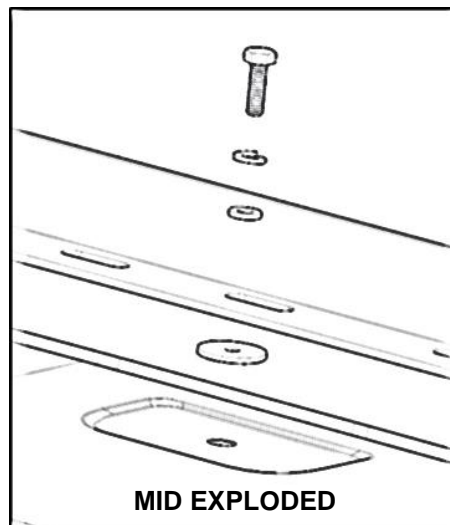
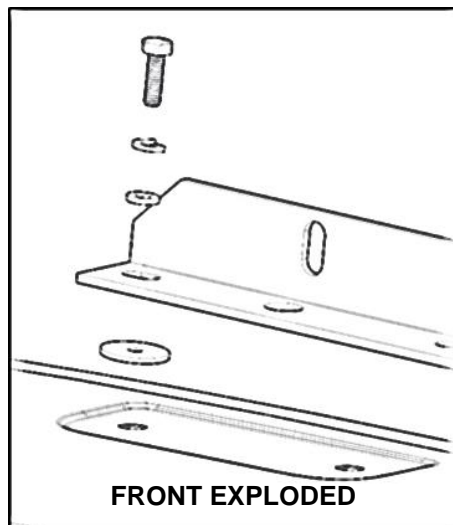

DO NOT EXCEED MANUFACTURERS WEIGHT CAPACITY FOR ROOF NV200/City Express Rail Installation

- Locate the 4 mounting locations shown on roof of van.
- Remove plugs from roof.
- Place the rail on the roof so the holes align with the threaded holes in roof and with approximately 1" between the rear of the rail and the rear door opening. In most installs, the rail upright flange is to the outside of the van.
- Insert rubber washer between the mounting rail and the roof to ensure sealing.
- Apply sealant on and around threaded holes and bolts threads to seal roof. (Passenger side shown)
- Install mounting rail as shown using M8 x 30mm bolts, 5/16" lock washers, and 5/16" flat washers. **Be sure to apply sealant around bolts as you fasten them. Note: Additional M8 x 20mm flat head screws are provided if mounting of feet interferes with bolts.**

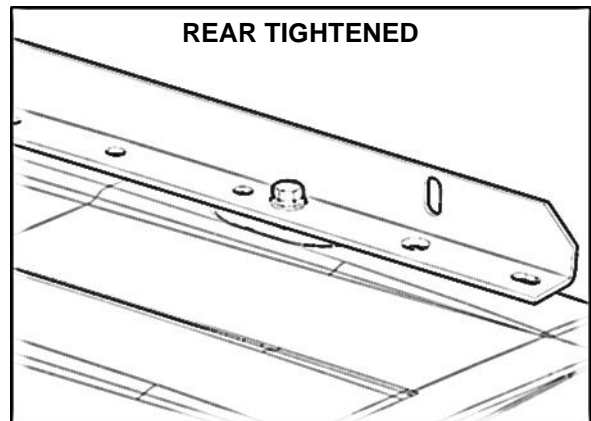
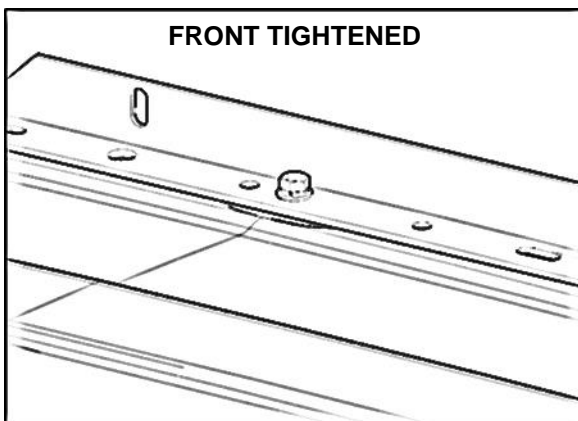
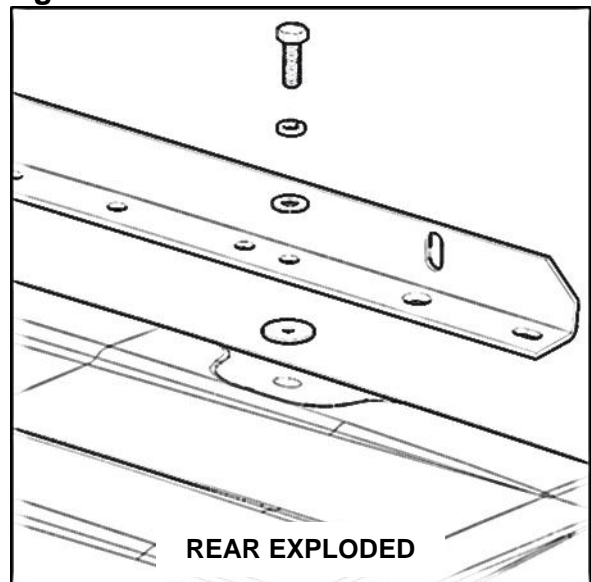
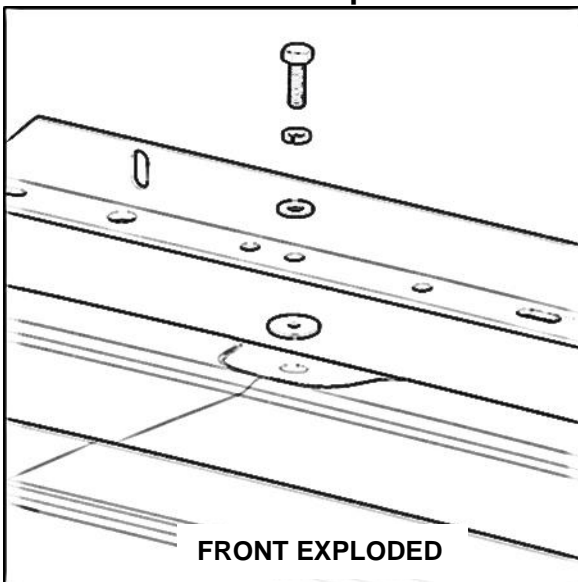
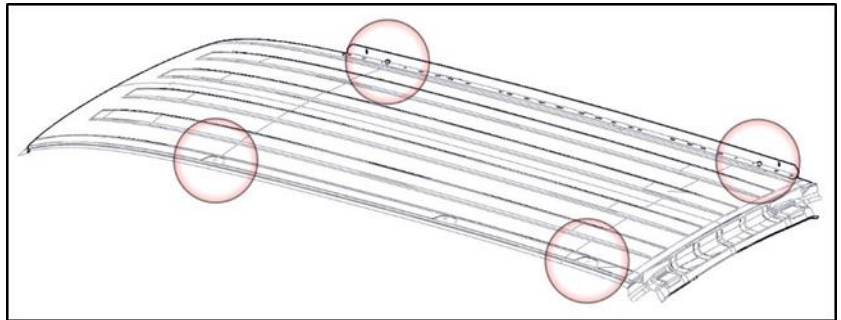

DO NOT EXCEED MANUFACTURERS WEIGHT CAPACITY FOR ROOF

Transit Connect Rail Installation

- Locate 4 mounting locations shown on roof of van.
- Remove plugs from roof.
- Place the rail on the roof so the holes align with the threaded holes in roof and with approximately 1" between the rear of the rail and the rear door opening. In most installs, the rail upright flange is to the outside of the van.
- Insert rubber washer between the mounting rail and the roof to ensure sealing.
- Apply sealant around holes in the roof and around bolt threads to seal roof. (Passenger side shown)
- Install mounting rail as shown using M8 x 30mm bolts and 5/16" flat washers on the outside. Use the 5/16" fender washer and M8 lock nut on the inside of the van. **Be sure to apply sealant on and around threads to seal roof.**

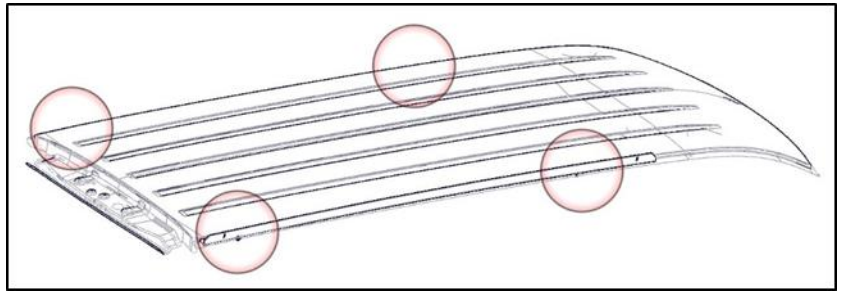

Note: Additional M8 x 20mm flat head screws are provided if mounting of feet interferes with bolts.

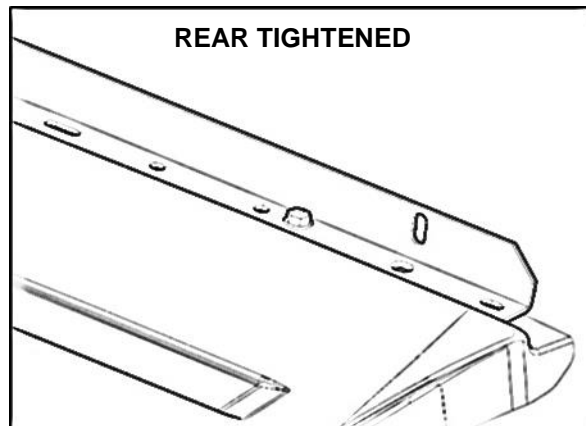
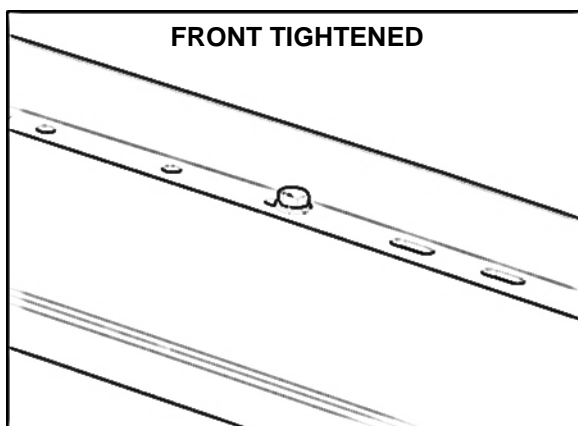
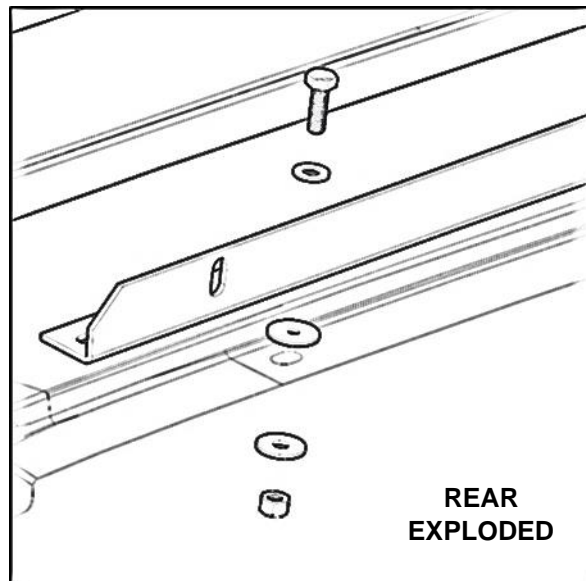
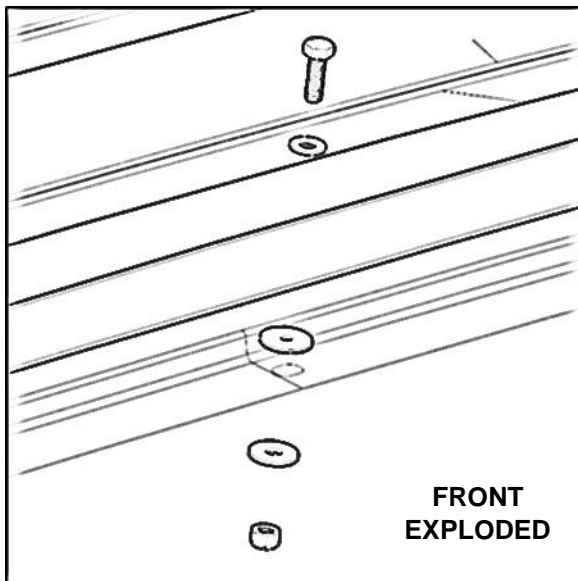

DO NOT EXCEED MANUFACTURERS WEIGHT CAPACITY FOR ROOF

Metris Rail Installation

- Locate 6 mount locations on van roof, 4 rear and 2 mid-roof, as shown.
- Remove plastic cap in these locations indicated to expose threads in the roof.
- Place the rail on the roof so the holes align with the threaded holes in roof and with approximately 5" between the rear of the rail and the rear door opening. In most installs, the rail upright flange is to the outside of the van.
- Insert rubber washer between the mounting rail and the roof to ensure sealing.
- Apply sealant on and around threaded holes and bolt threads to seal roof. (Passenger side shown)
- Install mounting rail as shown using M6 x 22mm bolts, 1/4" lock washers, and 1/4" flat washers on the outside. **Be sure to apply sealant around bolts as you fasten them.**

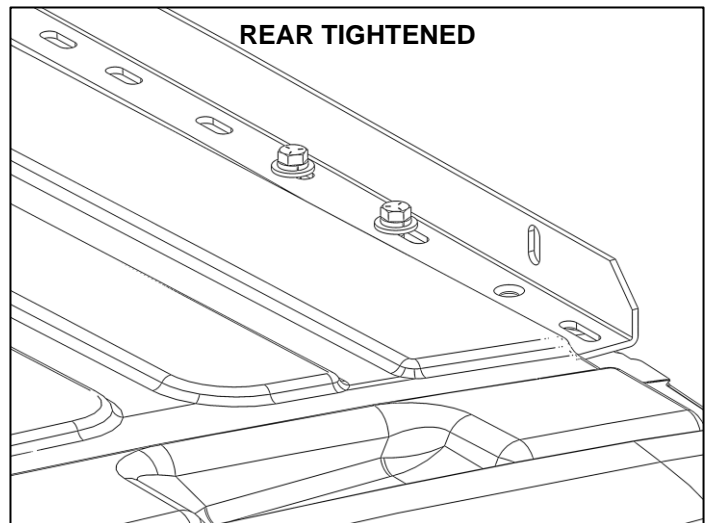
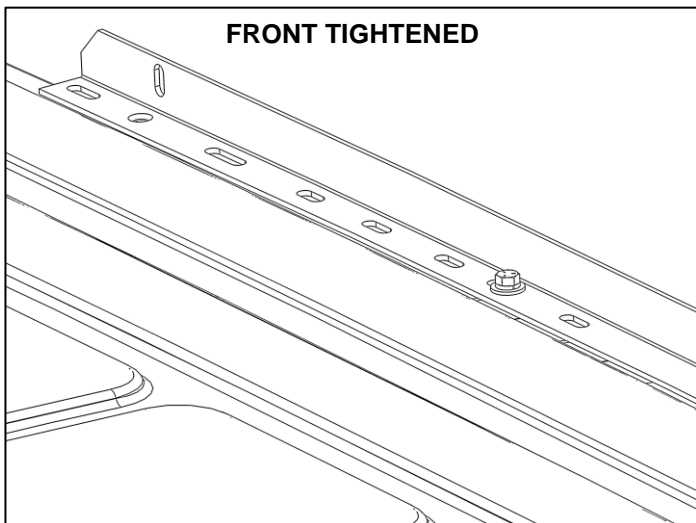
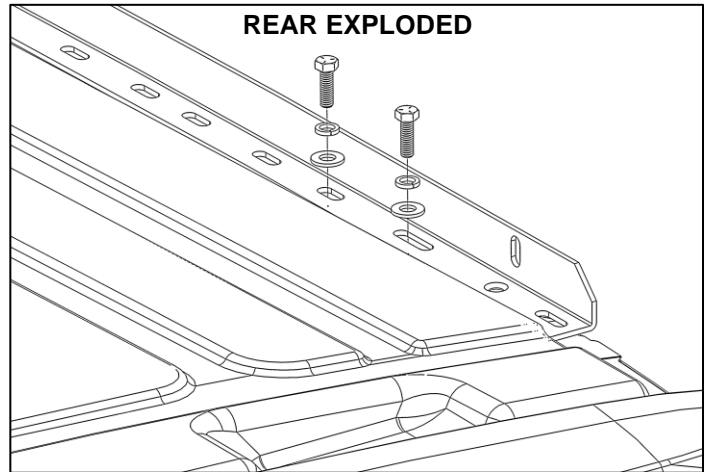
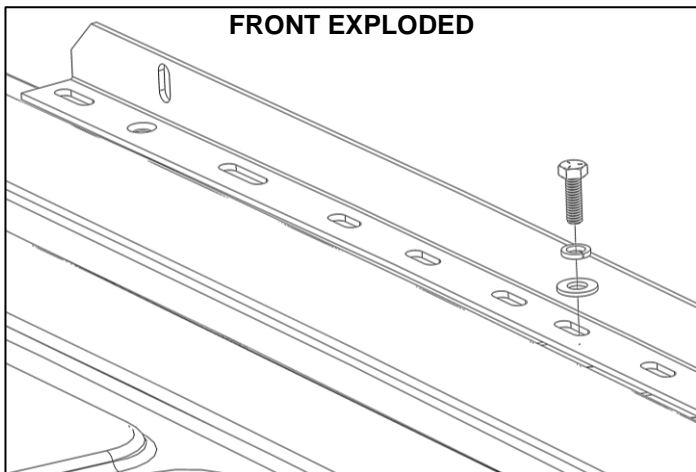
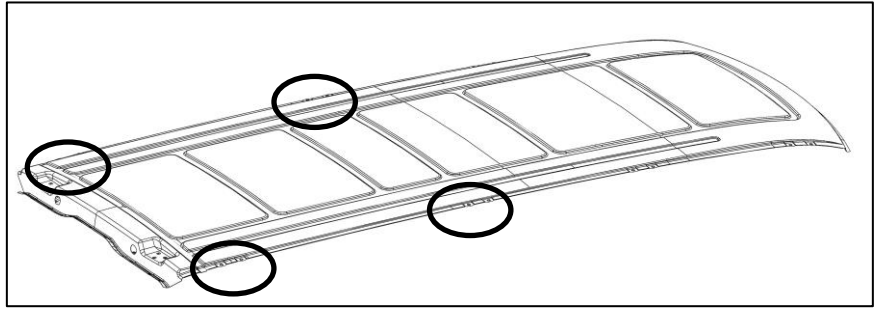

Assembly Instructions

Step 1 – Install End Stops

NOTE: If adding a rack onto the driver side, skip this step.

- Using 5/16" carriage bolts, 5/16" washers, and 5/16" lock nuts, bolt an end stop to the exposed end of each bow.
- TIGHTEN.

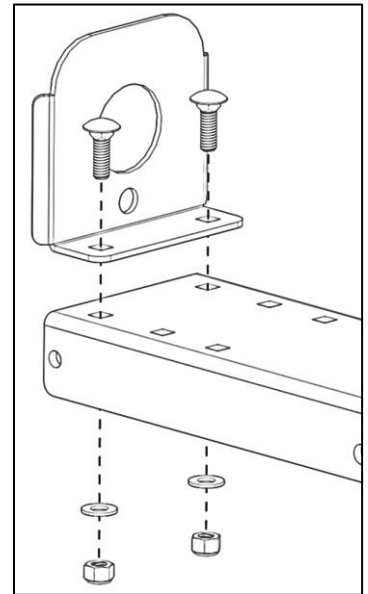
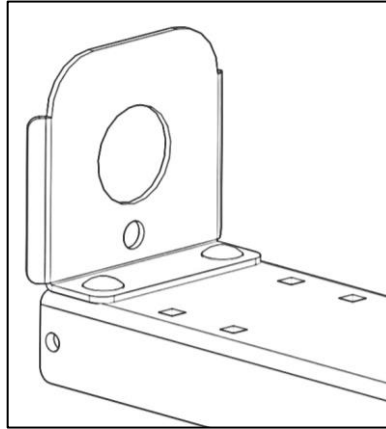

Step 2 – Determine Front and Rear Bows

- Determine front and rear bow. The rear bow will have a dampening mechanism attached. Notice the location of the triangular piece

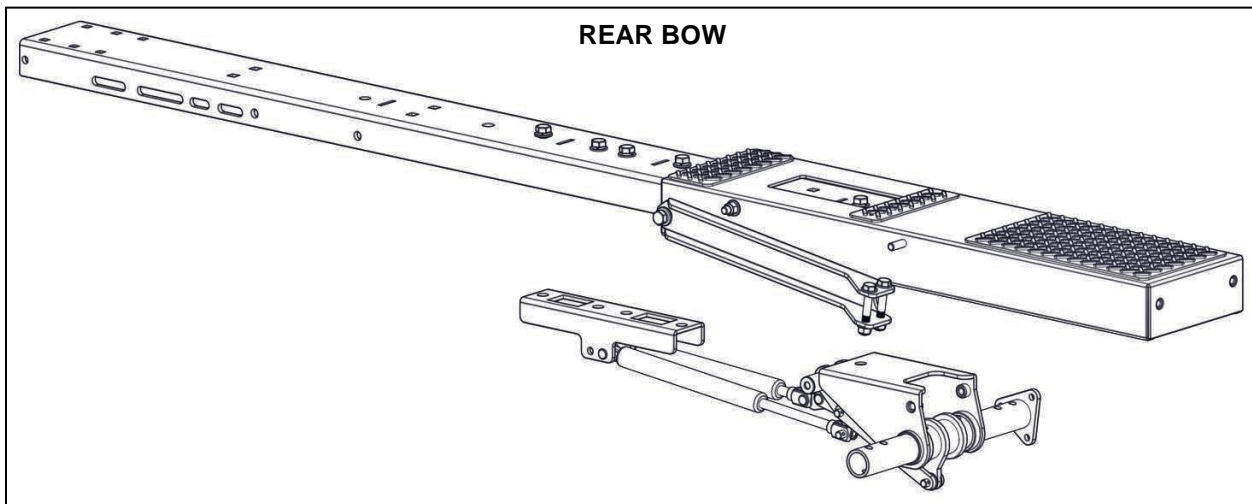
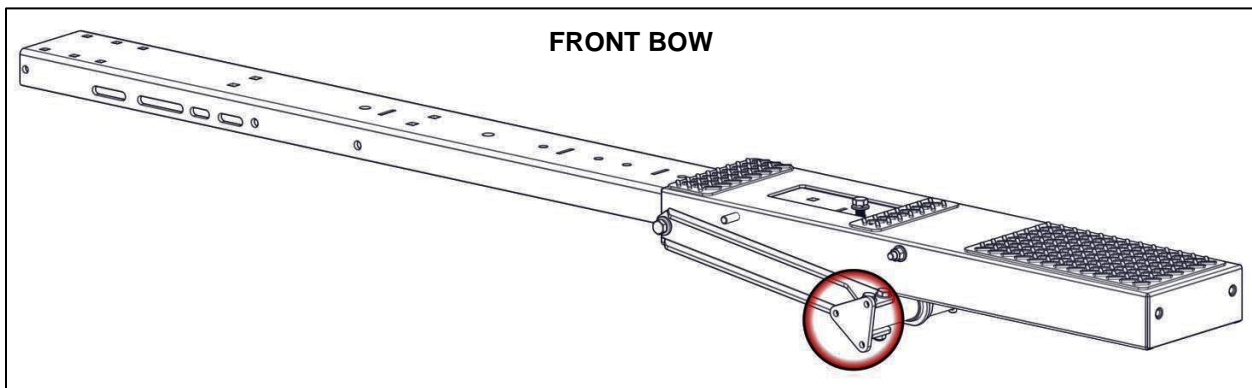

Step 3 – Mount Feet to Rails

- Locate the four mounting locations on the mount rails as shown below.

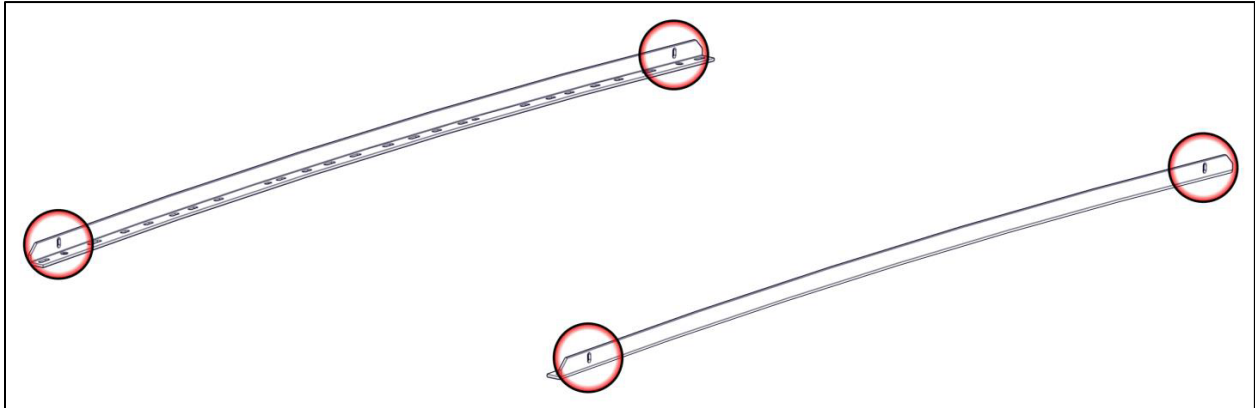

- Using 5/16" x 1" carriage bolts, 5/16" flat washers and 5/16" lock nuts, bolt the foot to the mount rail in the orientation shown.

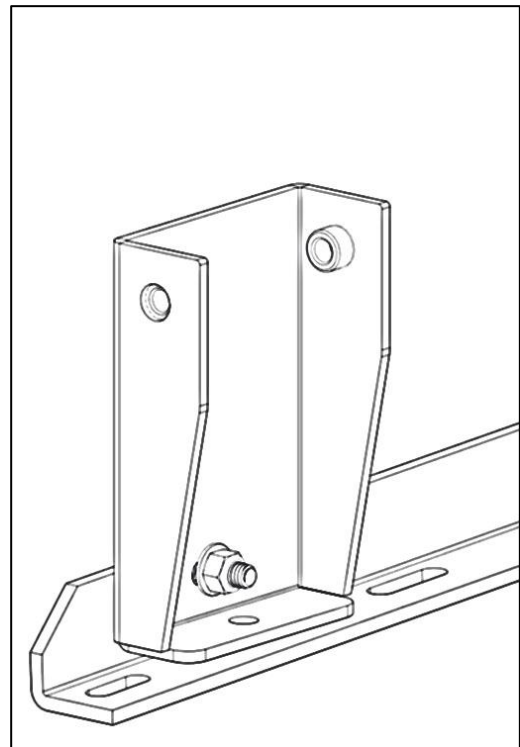
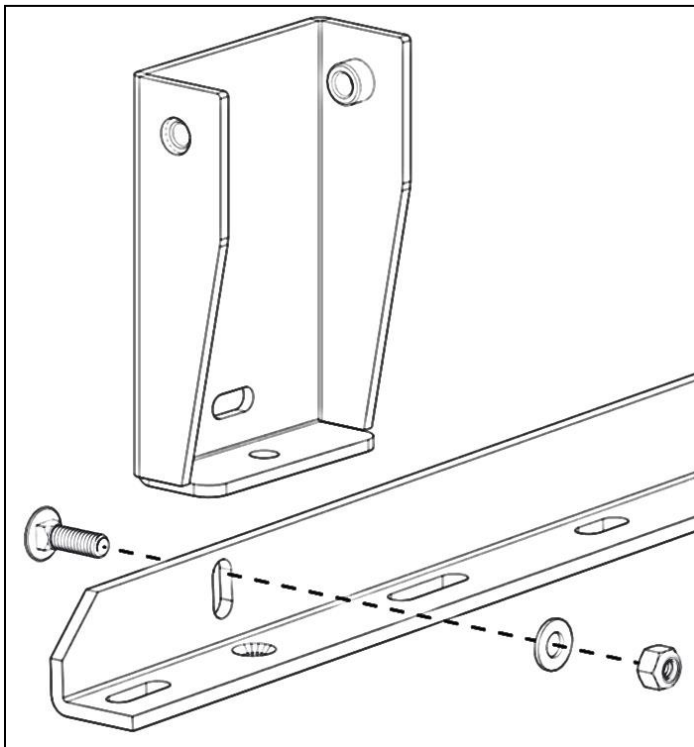

Step 4 – Place Bows on Feet

- Place the front bow on top of the front most mounts on the vehicle and the rear bow on the rear most mounts.
- **Be sure there is an equal distance from the center of the cross bow to each foot as shown below. The same slot, but on opposite ends of the bow should be used.**

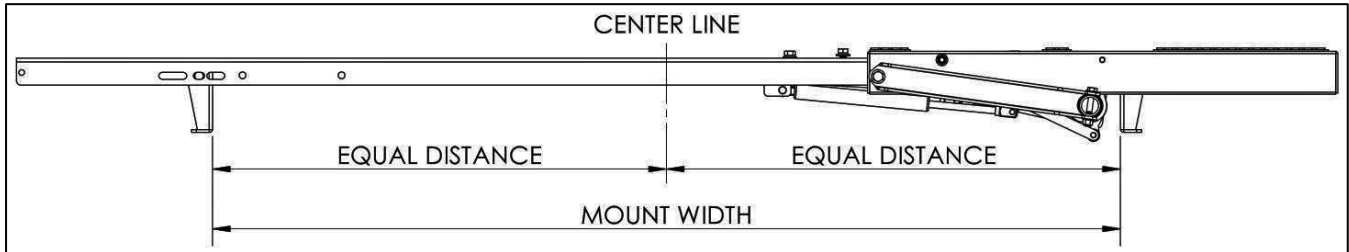

- Rotate the pan to expose the slots in the bow. Place a foam block from the packaging to hold the pan in an up position in order to access the mounting slots.
- Using 3/8" x 1" hex head bolts, 3/8" split lock washers and 3/8" flat washers, attach the bow to foot as shown.
- **DO NOT tighten hardware.** Leave hardware loose until the rack is assembled.
- Repeat these steps for installing remaining feet.

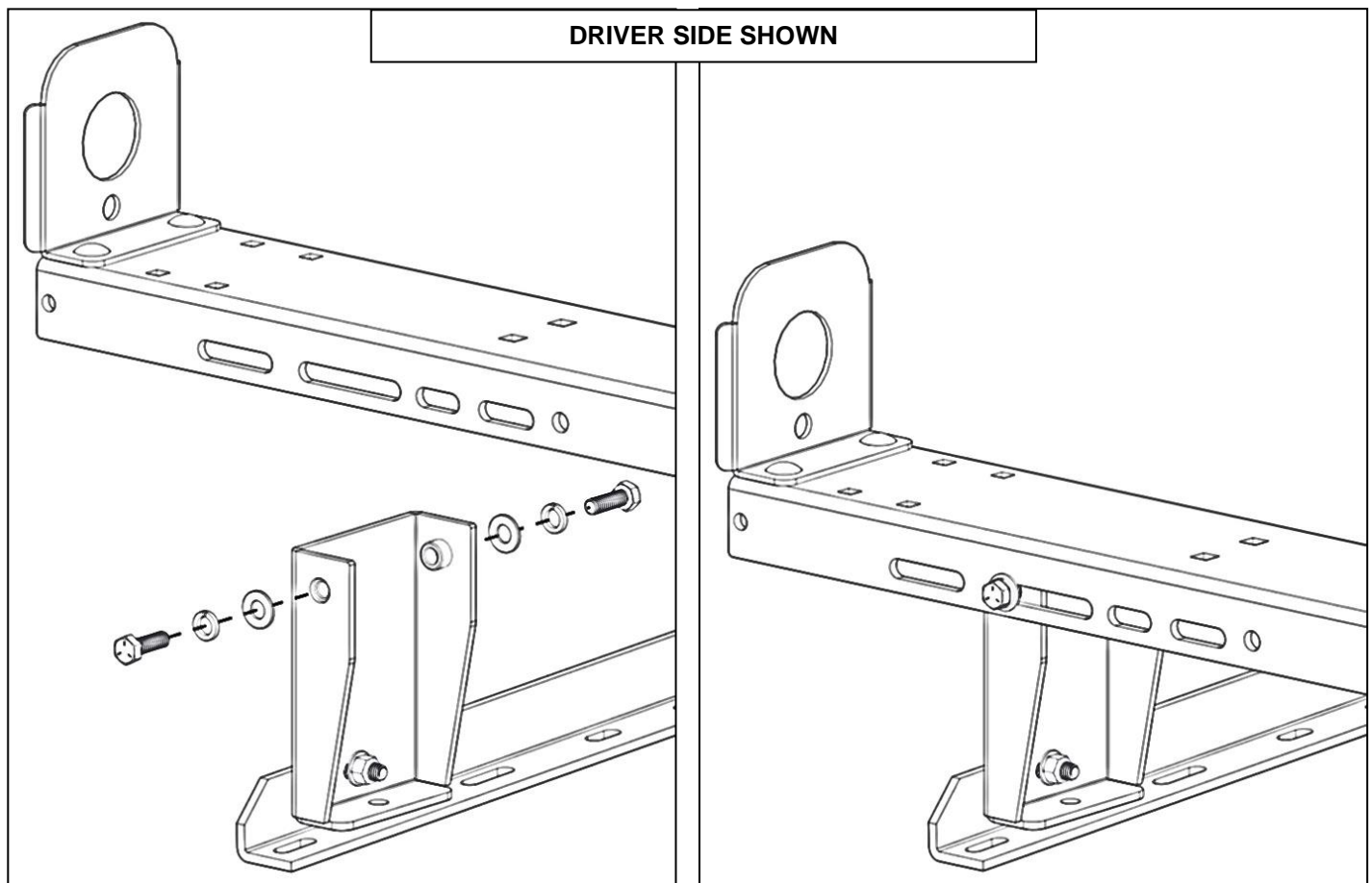

Step 5 – Install Torque Tube

- Bolt the torque tube to the front and the rear bow using a 1/4" x 1" hex head bolt, two 1/4" flat washers and a 1/4" lock nut at each location.

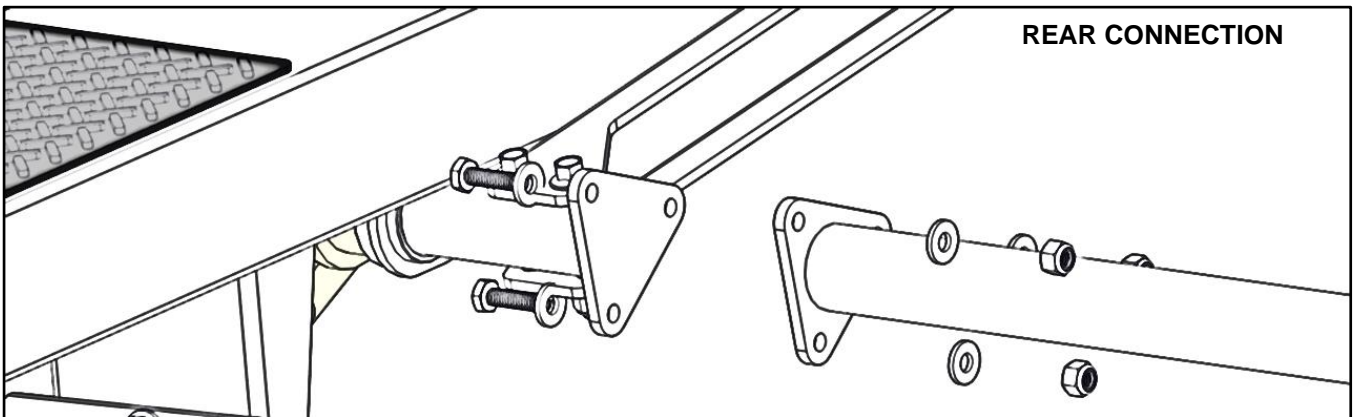
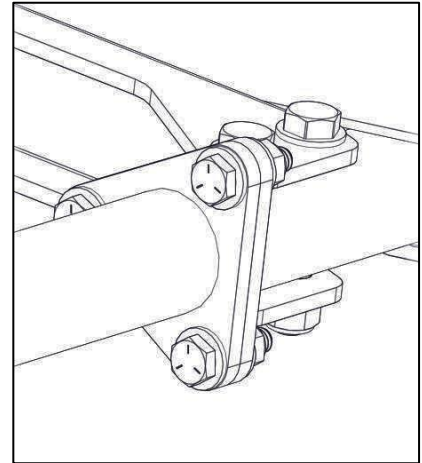
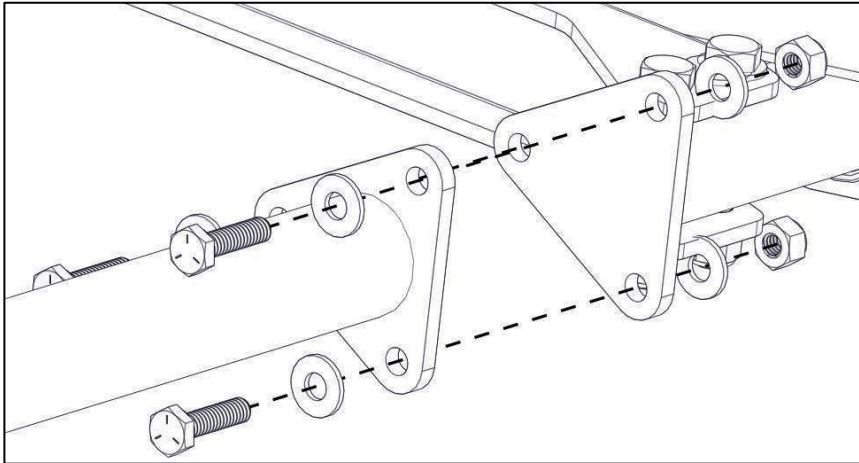
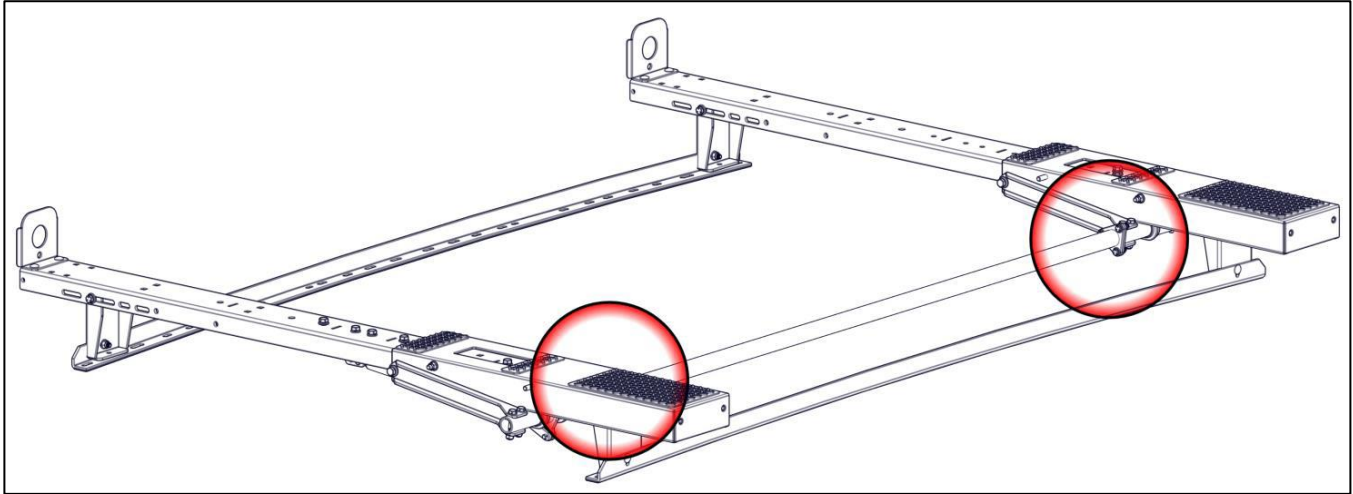

Step 6 – Install Ladder Pan Stiffener

- Using 3/8" x 3/4" hex heads, 3/8" lock washers and 3/8" flat washers, install ladder pan stiffener to the end of each bows pan assembly.
- TIGHTEN.

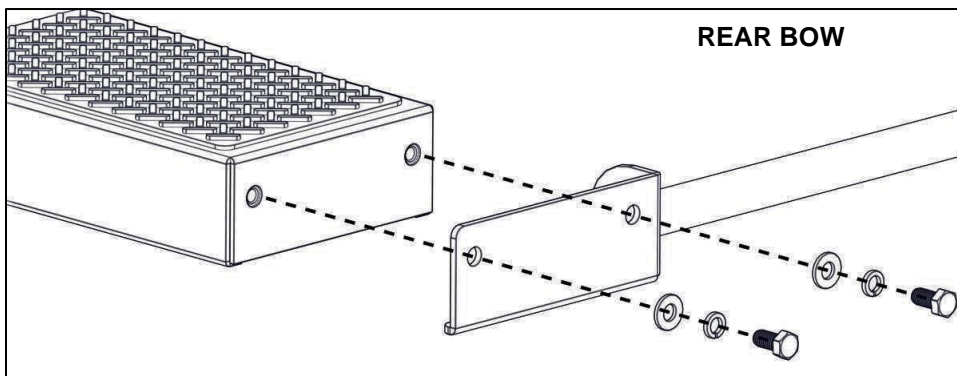
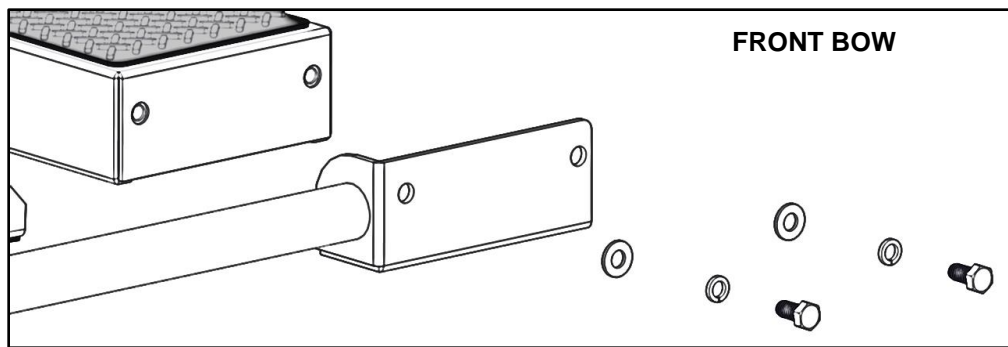
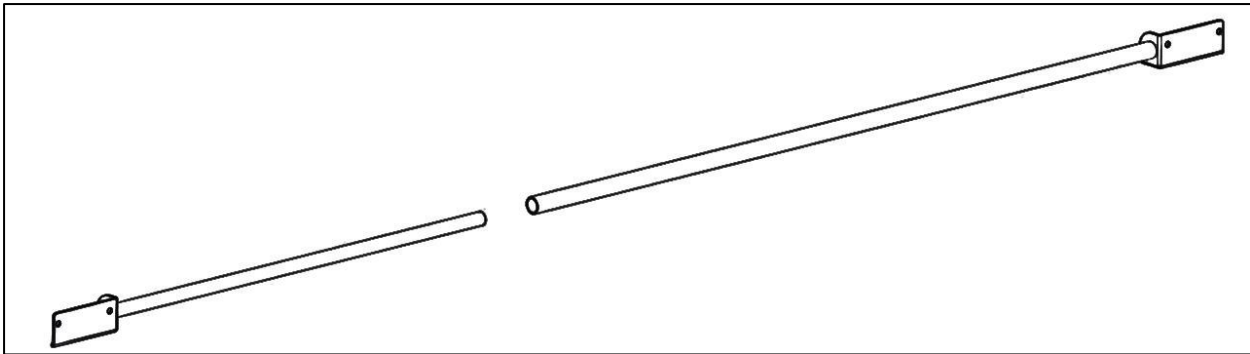
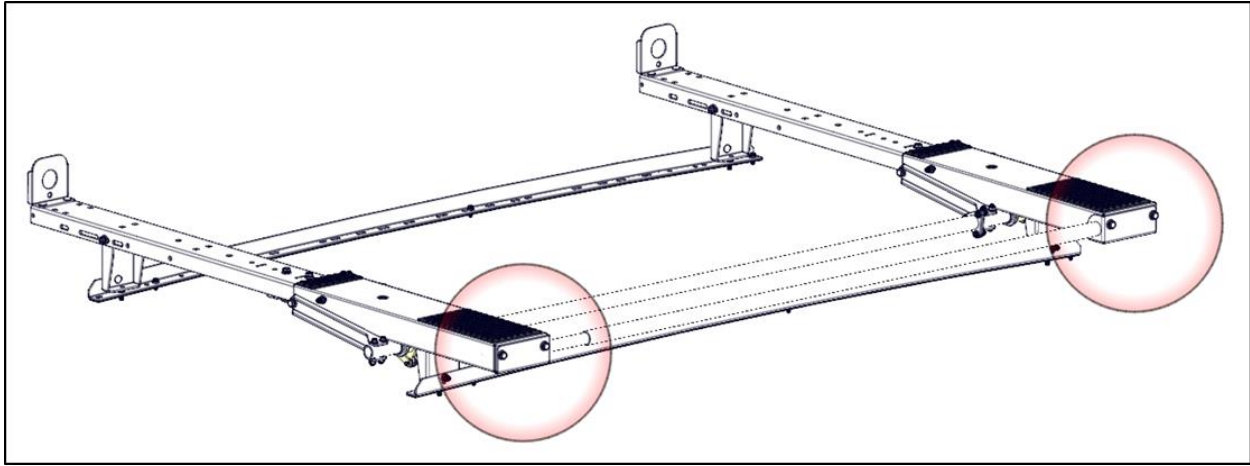

Step 7 – Install Ladder Hooks

- Determine which location the ladder hook and ladder stop need to be installed.
- Notice there are two studs protruding from each ladder pan.

Example 1:

- Both bows, lower positions are best for extension ladders.

Location of ladder clamps and stops for standard extension ladders.

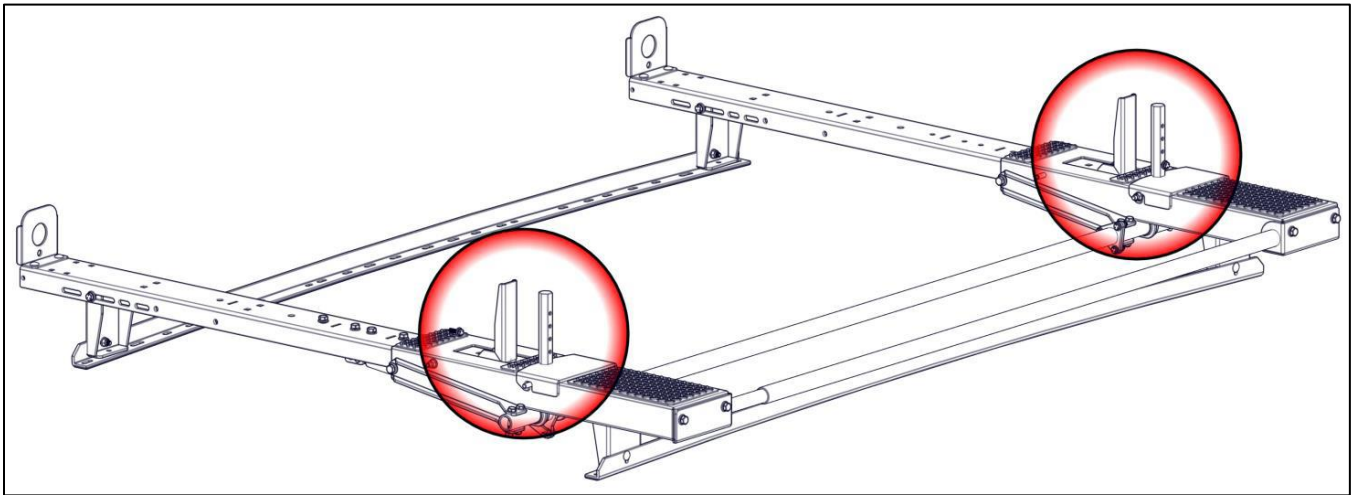

Example 2:

- Front bow, low position, Rear bow, upper position is best for common stepladders.

Location of ladder clamps and stops for standard stepladders.

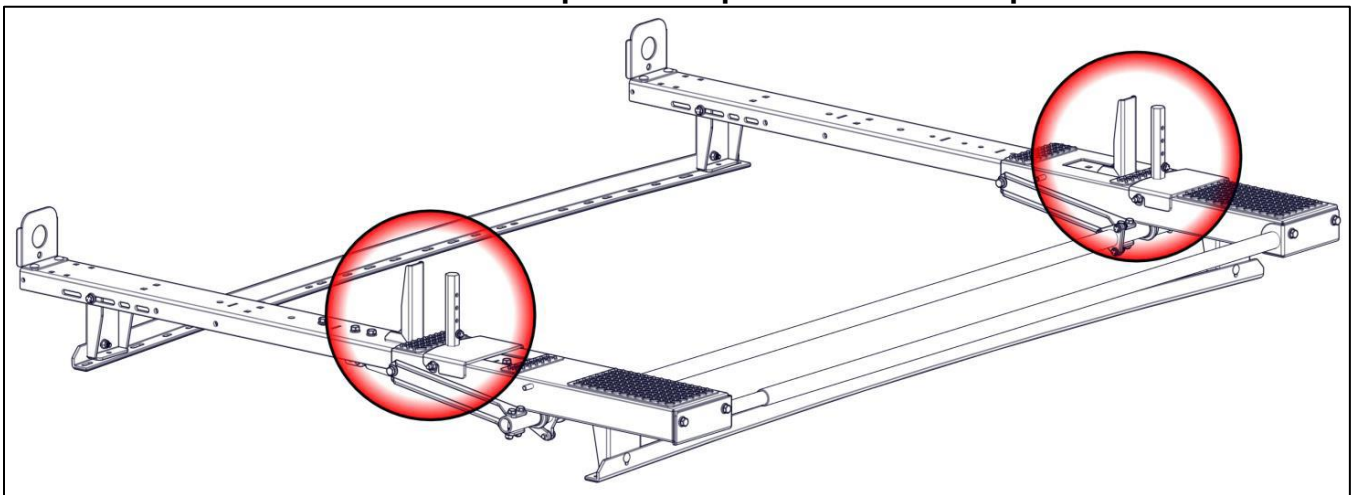

NOTE: In the rare instance the upper location on the front bow needs to be used, a 3/8" bolt and lock nut will need to be used to install the ladder stop.

- On the front bow, place the ladder hook base around the threaded studs in the desired location and attach using the pre-installed hardware.
- Position the ladder stop near the ladder hook base as shown. **Be sure the slot of the ladder stop aligns with the slot in the bow.**
- Bolt the ladder stop in place using a 3/8" x 1" hex head bolt, a 3/8" split lock washer and a 3/8" flat washer in the orientation shown.

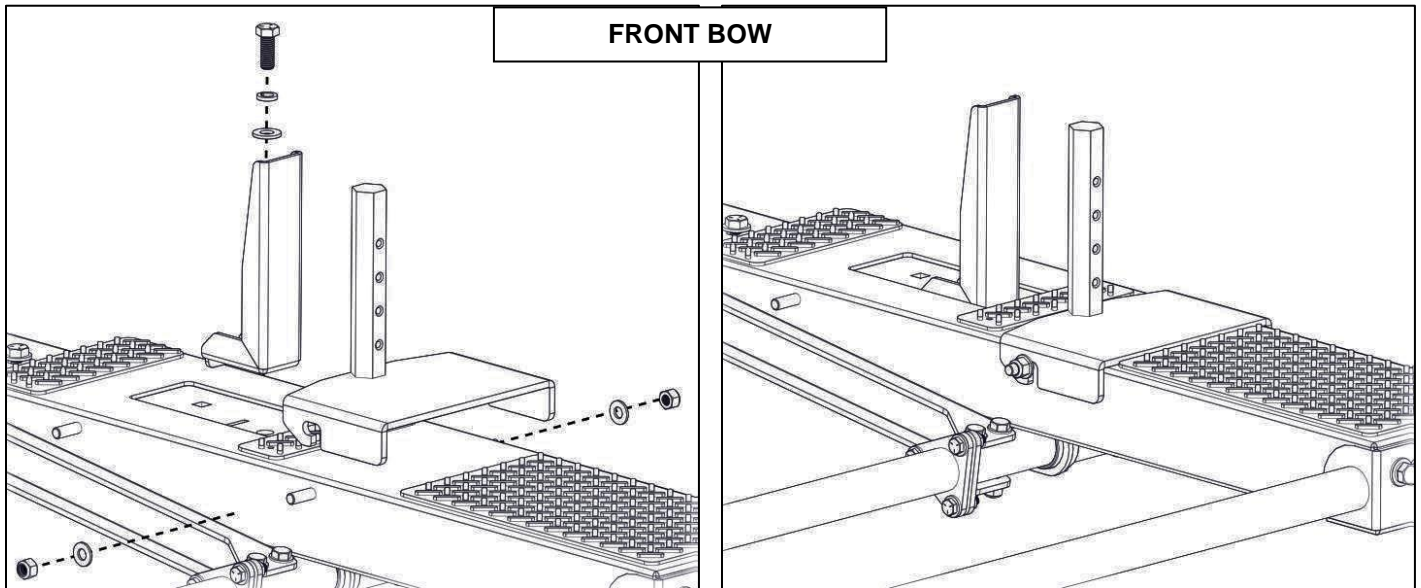

- On the rear bow, place the ladder hook base around the threaded studs in the desired location and attach using the pre-installed hardware as shown.
- Position the ladder stop near the ladder hook base as shown. **Be sure the slot of the ladder stop aligns with the slot in the bow.**
- Bolt the ladder stop in place using a 3/8" x 1" hex head bolt, a 3/8" split lock washer and a 3/8" flat washer in the orientation shown.

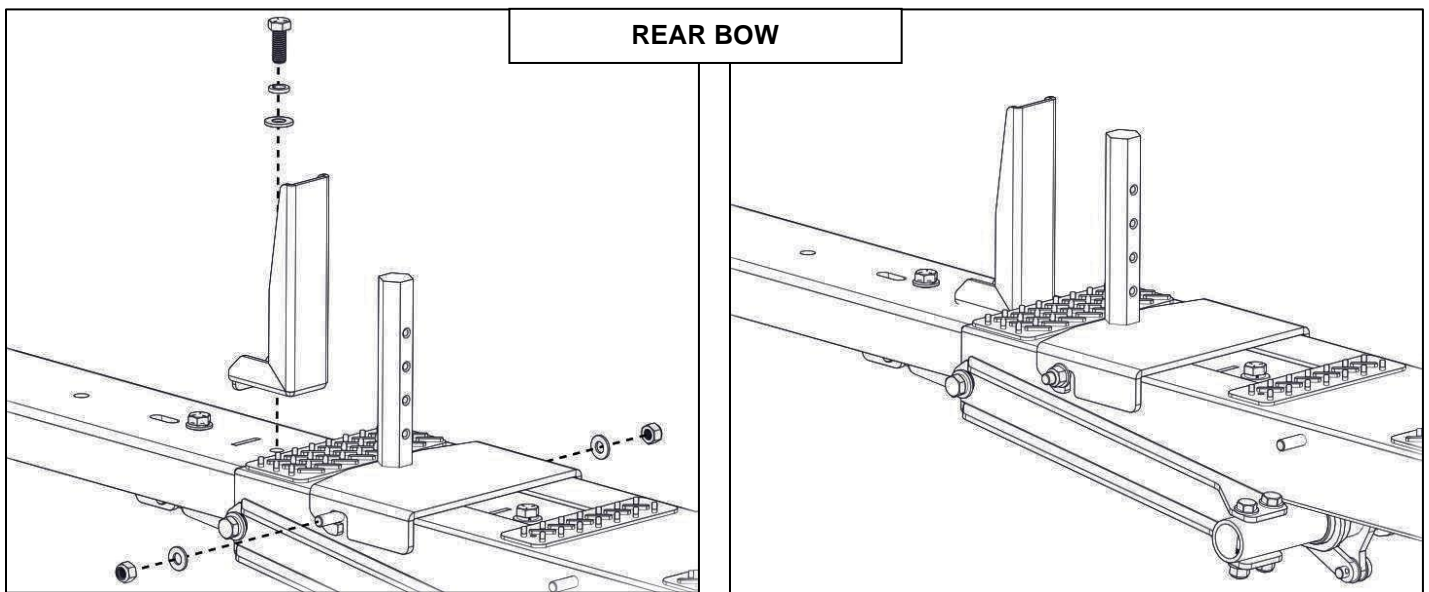

Step 8 – Install Latch

- Move rear pan assembly out of the way to expose the end of the cross member.
- Using 5/16" x 1" carriage bolts, 5/16" flat washers and 5/16" lock nuts, bolt through the middle set of square holes as shown.
- TIGHTEN.

NOTE: Shown without pan for clarity.

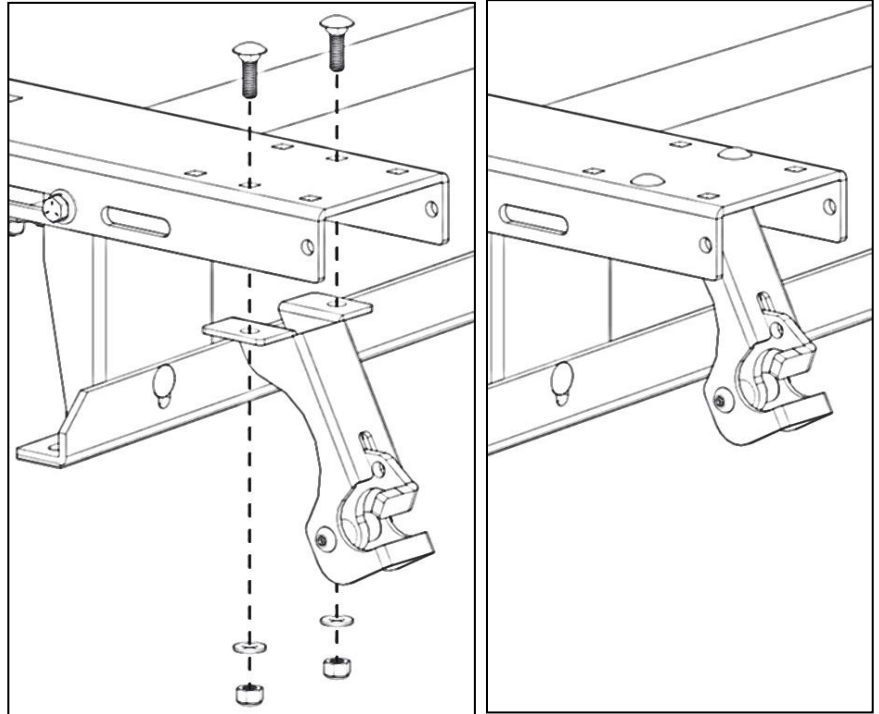

Step 9 – Install Handle

- Apply sealant to swaged end of handle.
- Use the hardware in the rear bow to bolt handle into position as shown.
- TIGHTEN.

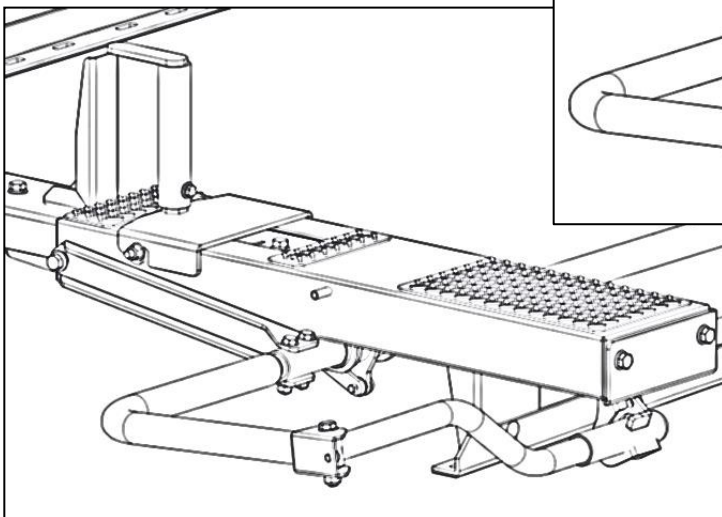
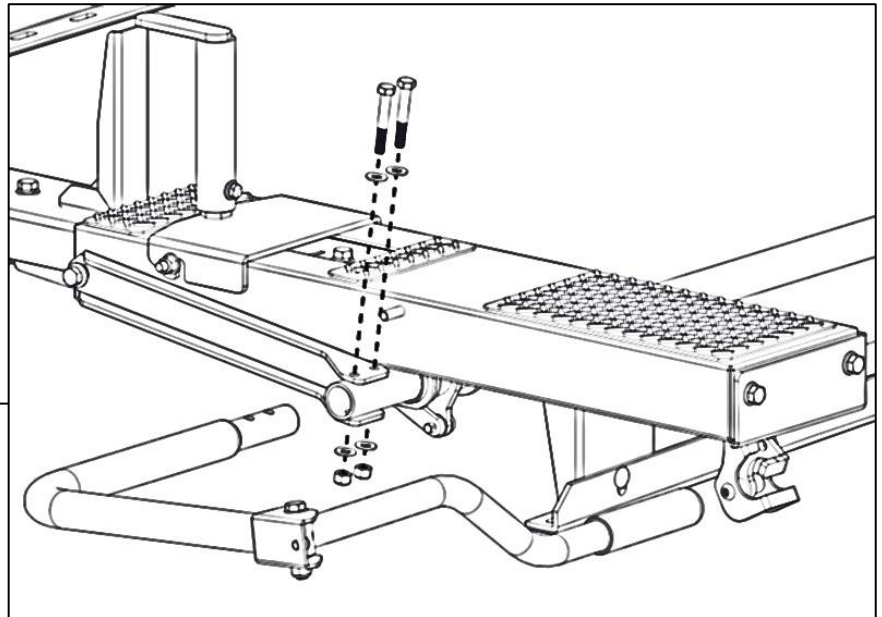

Step 10 – Assemble Ladder Hooks

Note: Before use the ladder hook must be adjusted to an appropriate height for the ladder that will be used. The height of the hook needs to be at least 1/4" greater than the ladder. The ladder should fit loosely on the hook, not snug.

- Measure the thickness of the ladder that will be used and determine the appropriate mounting hole on the ladder hook weldment that will allow for a loose fit.
- **Be sure the height of the hook is AT LEAST 1/4" GREATER THAN the thickness of your ladder.**
- If you are unsure of the thickness of the ladder that will be used, set the height of the hook to the highest setting (9 inches) and adjust it later.

NOTE: Roof height clearance is affected by the hook mounting location used. Please verify and be aware of the total height of the vehicle with rack installed.

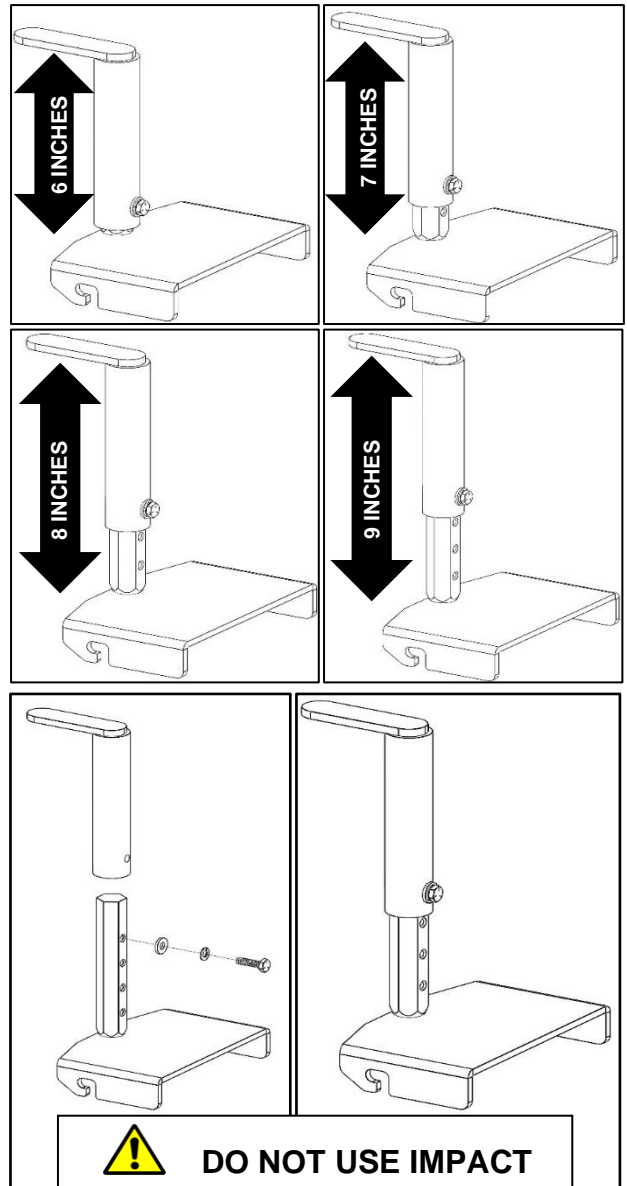

- Using a 1/4" x 1" hex head, a 1/4" lock washer and a 1/4" flat washer, bolt ladder hook assembly to ladder hook weldment using the previously determined mounting location.
- Tighten.

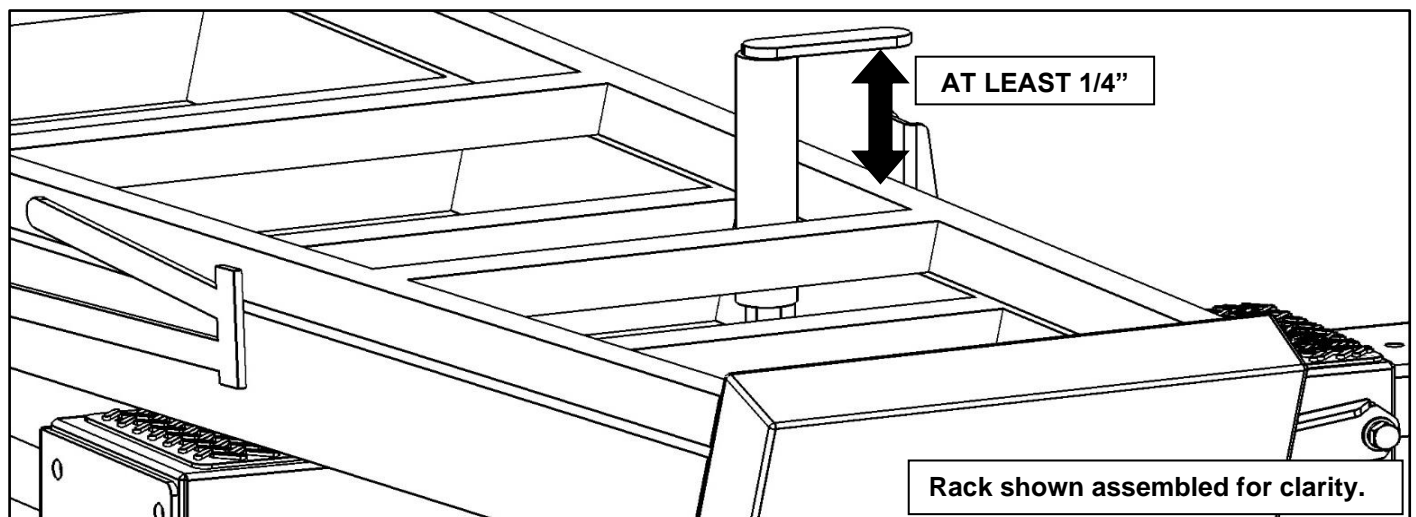

GO BACK AND ENSURE ALL HARDWARE IS TIGHT.

ASSEMBLY IS COMPLETE

